

BROADCAST NEWS



THE GRANDDADDY OF THE MAGIC EYE

PUBLISHED BY
RCA MANUFACTURING COMPANY, INCORPORATED
Camden, New Jersey



RCA Manufacturing Company, Inc.

A Radio Corporation of America Subsidiary

Camden, N. J.

"RADIO HEADQUARTERS"

DAVID SARNOFF, Chairman of the Board

E. T. CUNNINGHAM, President	G. K. THROCKMORTON, Executive Vice-President
L. B. MORRIS, Vice-President and General Counsel	J. C. WARNER, Vice-President and General Mgr., RCA Radiotron Div.
W. R. G. BAKER, Vice-President and General Manager, RCA Victor Div.	J. M. SMITH, Vice-President in Charge of Mfg., RCA Radiotron Div.
LEWIS M. CLEMENT, Vice-President in Charge of Research and Engineering, RCA Victor Div.	J. T. CLEMENT, Vice-President in Charge of Washington, D.C., Office
J. W. BURNISON, Vice-President in Charge of Mfg., RCA Victor Div.	J. D. COOK, Treasurer
	E. F. HAINES, Assistant Treasurer
	P. G. McCOLLUM, Comptroller
	E. J. SCHNEIDER, Assistant Comptroller
	F. H. CORREGAN, Vice-President and Secretary
	DAVID MACKAY, Assistant Secretary
	C. B. MYERS, Assistant Secretary
	F. H. TROUP, Assistant Treasurer and Assistant Secretary

F. R. DEAKINS, Manager
ENGINEERING PRODUCTS DIVISION
AND INTERNATIONAL DIVISION

TRANSMITTER SALES SECTION

(OF ENGINEERING PRODUCTS DIVISION)

I. R. BAKER, Manager

S. W. GOULDEN, Commercial Engineer	T. A. SMITH, C. B. S. Contact
J. P. TAYLOR, Sales Engineer	C. L. BEACH, N. B. C. Contact
A. R. HOPKINS, Sales Engineer	P. A. ANDERSON, Police Radio Sales
BEN ADLER, Power Tube Sales	T. W. ENIS, Power Tube Sales

E. T. JONES, Engineering Products Advertising

- 1 **EASTERN DISTRICT**—T. A. Smith, Manager, 1270 Sixth Ave., New York City; R. P. May, Assistant

MAINE	RHODE ISLAND	NEW JERSEY	WEST VIRGINIA
VERMONT	CONNECTICUT	PENNSYLVANIA	DELAWARE
NEW HAMPSHIRE	NEW YORK	MARYLAND	VIRGINIA
MASSACHUSETTS	PUERTO RICO	NORTH CAROLINA (Broadcast)	
- 2 **CENTRAL DISTRICT**—H. C. Vance, Manager, 111 North Canal St., Chicago, Ill.; B. A. Wilson, Assistant

NORTH DAKOTA	MISSOURI	ILLINOIS	OHIO
SOUTH DAKOTA	IOWA	INDIANA	MICHIGAN
NEBRASKA	MINNESOTA	KENTUCKY	KANSAS CITY (KANSAS)
WISCONSIN			
- 3 **WESTERN DISTRICT**—W. H. Beltz, Manager, 170 Ninth St., San Francisco, Calif.; Edmund Frost, Assistant

WASHINGTON	IDAHO	UTAH	MONTANA
OREGON	NEVADA	ARIZONA	WYOMING
CALIFORNIA	HAWAII (Police)	ALASKA (Police)	
- 4 **SOUTHWESTERN DISTRICT**—W. M. Witty, Manager, Santa Fe Bldg., Dallas, Texas

TEXAS	ARKANSAS	KANSAS (Except Kansas City)	NEW MEXICO
OKLAHOMA	LOUISIANA (Except New Orleans)	COLORADO	
- 5 **SOUTHEASTERN DISTRICT**—D. A. Reesor, Manager, 144 Walton St., N. W., Atlanta, Ga.

TENNESSEE	SOUTH CAROLINA	ALABAMA	FLORIDA
NORTH CAROLINA (Police)	GEORGIA	MISSISSIPPI	NEW ORLEANS (LA.)

BROADCAST TRANSMITTERS

POWER RADIOTRONS

POLICE TRANSMITTERS

POLICE RECEIVERS

SPECIAL COMMUNICATION EQUIPMENT

BROADCAST NEWS

REG. U. S. PAT. OFF.

E. T. JONES
Editor

PAUL V. LUTZ
Associate Editor

NUMBER 17

SEPTEMBER, 1935

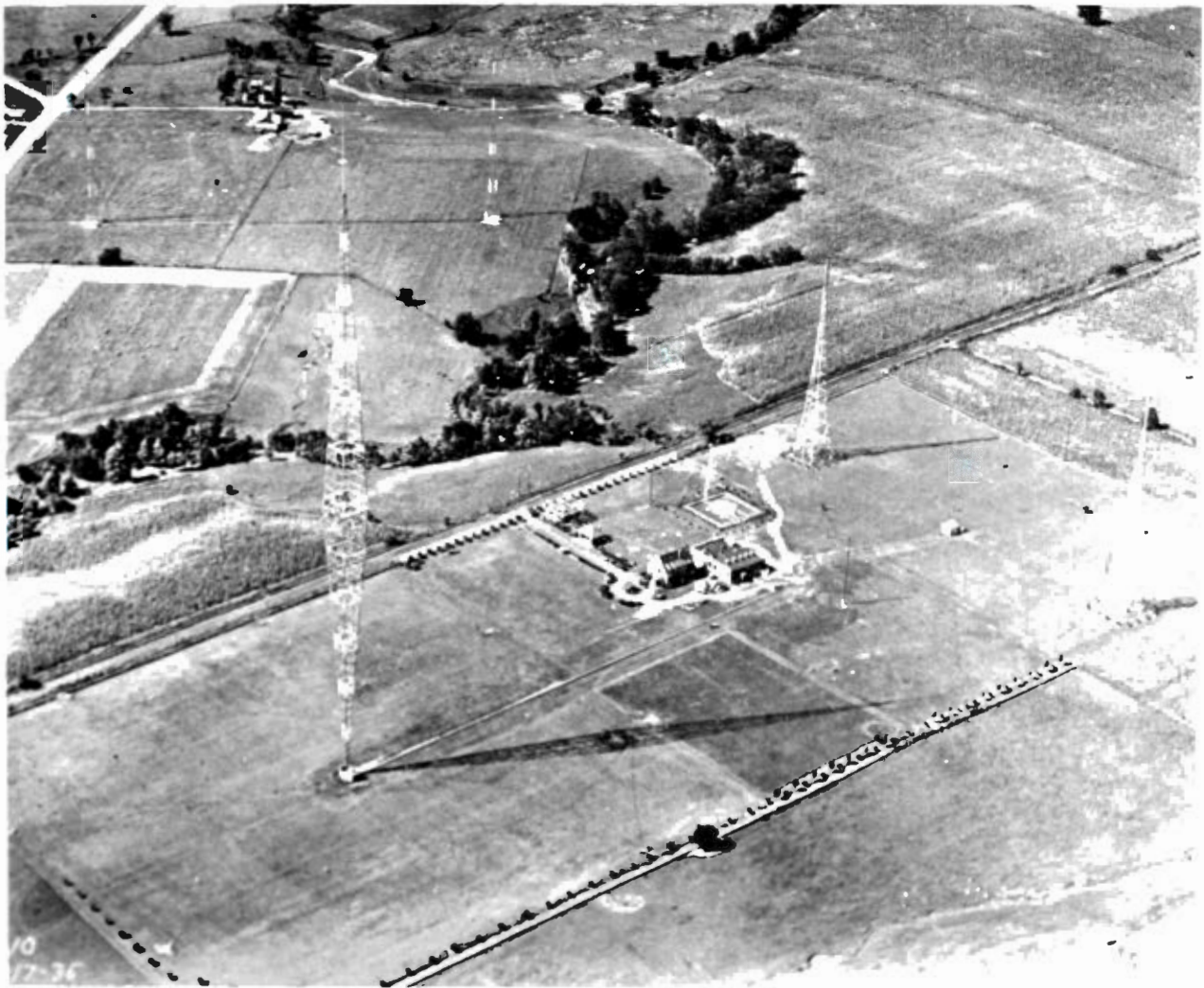

NEW HAVEN, CT. RADIO STATION WLW. (10-17-35)

Published Bi-Monthly in the Interest of the Radio Broadcasting Industry
and Copyrighted, 1935, by the
RCA MANUFACTURING COMPANY, INC
CAMDEN, NEW JERSEY, U. S. A.

"City Voices" An Unusual Program

NBC Feature Increasing in Popularity

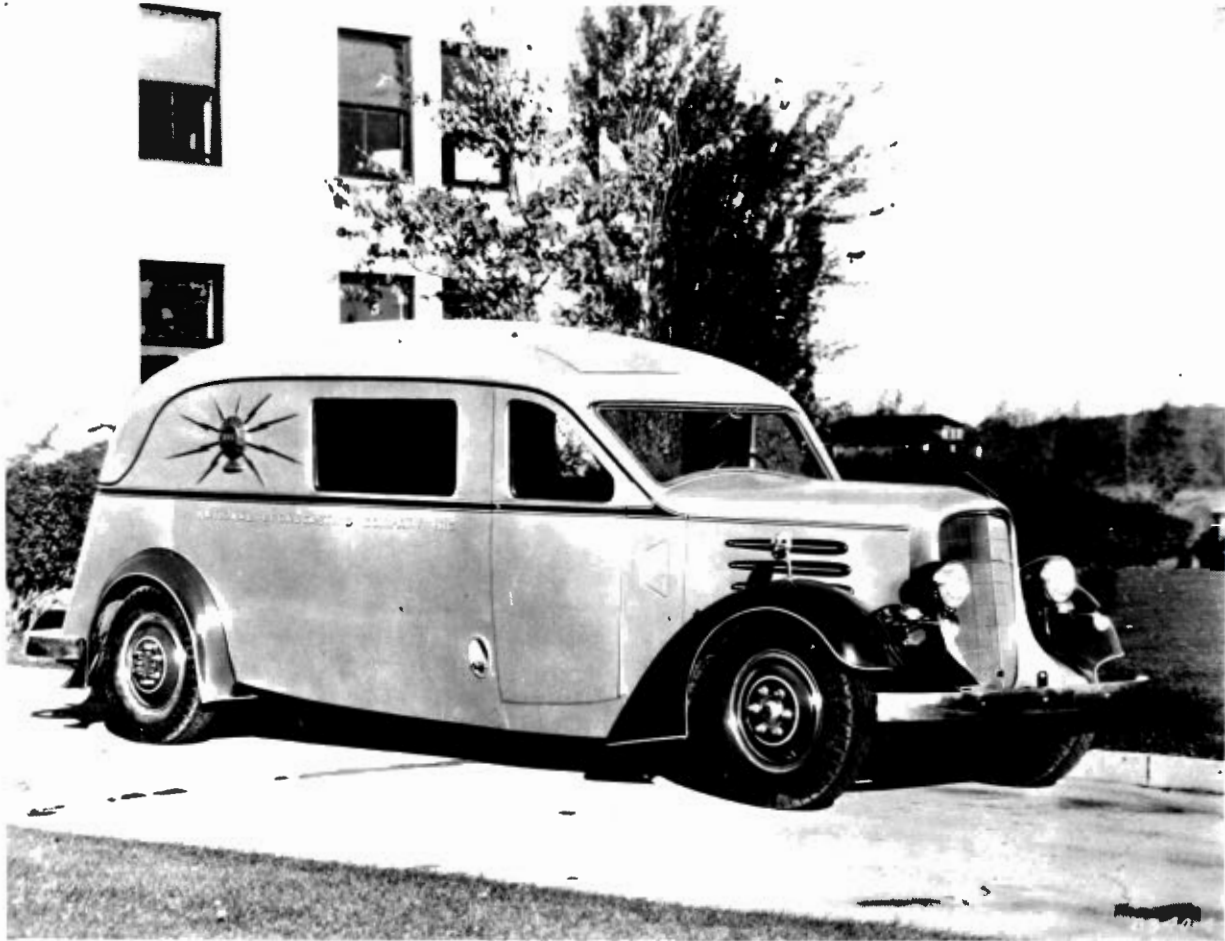

The studio on wheels.

HAROUN EL RASCHID, the Oriental ruler who roamed throughout his country in disguise to see what he could see, has a modern counterpart in radio. The principal points of difference between this wandering Sultan of old and the American roamer of 1935 lies in the utter lack of disguise carried by the modern version and the fact that instead of bringing intriguing sights to a lone emperor actual sounds plus a verbal description of interesting scenes and activities are brought to an entire nation.

Today's wandering witness is the National Broadcasting Company's mobile unit,—an eight-ton broadcasting station mounted on

an automotive chassis,—and the program produced thereby is known as "City Voices," a twice weekly network feature.

Better able to get about than any sultan, no matter how well disguised, yet, a better traveler than even a sultan's magic carpet, it wends its way through the busy sections of America's biggest cities revealing to listening millions little known facts about well known places, industries and persons. Already it has taken the radio audience, in effect, for a trip through Coney Island and a ride on the chute-the-chutes; high above New York's East River to hear workmen spinning the cable to support the new Tri-Borough

Bridge; far below the city's surface and beneath the Hudson River to listen to other workmen digging the new Weehawken tunnel; for a ride on the Staten Island Ferry to hear the noises of Manhattan's unparalleled harbor during the morning rush hour while the commuters in interviews tell of their daily routine; to the repair yards of New York's Independent Subway; through Chicago's stock yards; to one of Gotham's few remaining blacksmith shops; for a trip through Brooklyn's new zoo in Prospect Park; to inspect the Diesel Motor plant in Cleveland and to the Bide-a-Wee Home for dogs in New York. These are some of the City Voices.

Informal, instructive and highly entertaining, this series of "City Voices" programs, conceived by John Royal, NBC's vice president in charge of programs, and supervised by William Lundell, NBC's director of special events, gives off an atmosphere of genuine spontaneity. The mobile unit which makes these broadcasts possible is a model of engineering ingenuity.

The unit has three transmitters capable of operating on both ultra-high and intermediate frequencies, although only an ultra-high frequency wave is employed on the "City Voices" broadcasts. Carrying its own gasoline driven generator capable of developing alternating current at 220 volts, the unit can broadcast at a standstill, while moving at parade speed or while whizzing along at 70 miles an hour. It seldom transmits at such great speed, however. Since it has a transmitting range which seldom exceeds 25 miles, its signals would soon fade if it were at a greater distance from the receiving station.

Aboard the unit on the average "City Voice" program are three engineers. The broadcast from the unit, when it is operating in the vicinity of New York City, is usually received on the roof of the RCA Building in Rockefeller Center. The received program is carried by wire to the Master Control room in Radio City where engi-

As a part of the equipment appears in the rear of the unit.

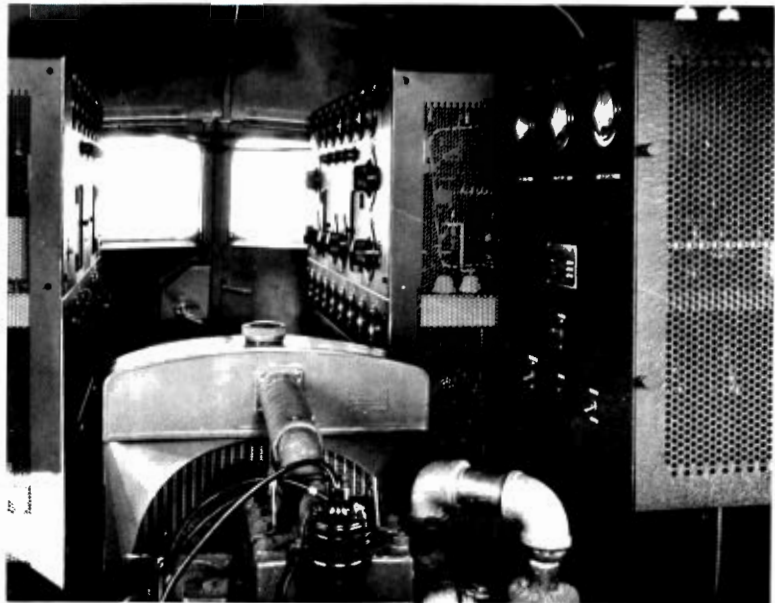

Showing the compact arrangement of equipment in the NBC Mobile Sound Unit.

neers relay it into regular broadcast channels.

Program directors and engineers in Radio City converse with those aboard the mobile unit through the NBC transmitting station W2ZDG, atop the Empire State Building. The call letters of the mobile unit are WIOXV.

In the broadcast of some programs, NBC uses two receiving locations in New York. The roof of the City Bank building is frequently used for this purpose. The four receiving sets on the mobile unit are capable of operation on a wide range of frequencies. Two of the transmitters aboard have 150-watt capacity while the third is a 15-watt transmitter.

The National Broadcasting Company maintains two of these mobile units. One is stationed in New York, the other in Chicago and both have been used on "City Voices" broadcasts. The Chicago unit was employed on the Cleveland and Chicago stock yard programs.

These "City Voices" programs, striking a new note in radio entertainment, have registered a hit with the listening public because they bring actual, vivid representations of scores of places, persons and things that nearly everyone has heard about and that millions long to witness.

In no other way can the zest and flavor of everyday life be brought to the ears of so many millions of listeners. The sights, the sounds, the scenes that are prosaic to the actual participants, have an element of mystery and glamor for those who do not come into daily contact with them. For the multitude of radio "fans" who crave the new and unusual, the "City Voices" program is the piquant sauce which gives added savor to the daily menu of ordinary broadcasts.

Unlimited in scope, with an entire nation's scenic wonders, its industries, its peoples and their work and hobbies waiting to supply the interest for future City Voices programs, the series is bound to grow more popular with each broadcast. The City Voices of today seem destined for expansion into the Nation's Voices of tomorrow. The programs intensify human interest, bringing to a whole country that very thrill which an emperor of long ago, with all his wealth and power, sought almost vainly to obtain.

The few minor problems which remain to be solved present no great difficulties and it is quite probable that with their solution the perfection and desired flexibility of these programs will be assured.

Microphone Progress

By JOSEPH D'AGOSTINO, NBC Publicity Division

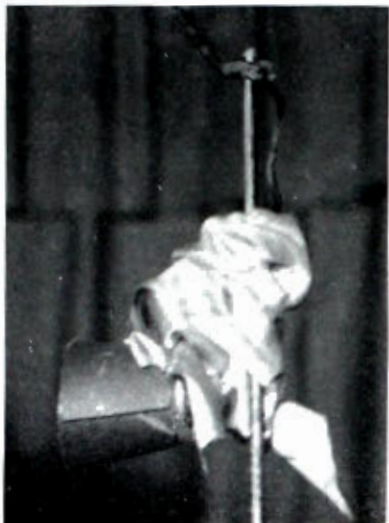

No. 1—The carbon microphone (telephone transmitter) adapted to broadcast work. Used at station **WDY**, operated by **RCA** at Aldene, New Jersey, in 1921.



Joseph D'Agostino



No. 2—The "dishpan" microphone—used at station **WDY** at Aldene, New Jersey, 1921-1922.

THE microphone, in the popular mind, has come to be the symbol of radio broadcasting, and perhaps this is rightly so for the development of the microphone has closely paralleled the development of broadcasting.

From the early experimental days of radio, when an ordinary telephone set was used, up to the present time, when the high-fidelity "velocity" microphone is stand-

ard equipment, there has been a constant improvement in this important part of broadcasting facilities. This has resulted, to a very considerable extent through the continuous labors of the research engineers of the National Broadcasting Company in collaboration with RCA Manufacturing Co. Inc.

In the NBC museum at Radio City there is now an interesting exhibit of microphone equipment,

old and new, which traces this development.

The first "mike," as has been said, was a telephone transmitter type. When a new instrument was developed, it was virtually unchanged except in appearance. It had a paper diaphragm much resembling a loudspeaker cone and was known as a "Phonotron," or "Dishpan" microphone. It was used in broadcasting as late as 1922.

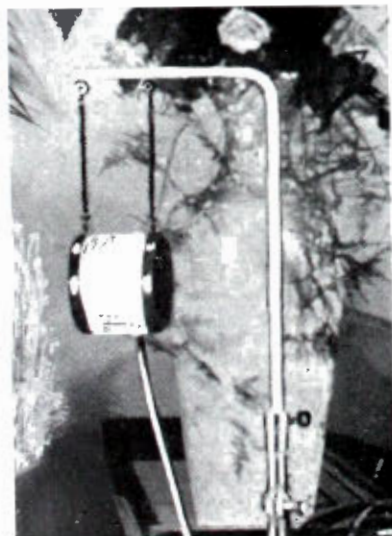

No. 3—The "Tomato Can" microphone, first used at stations **KDKA** and **WJZ** in 1922.



No. 4—The "Lyre," a carbon microphone mounted in a decorative housing.

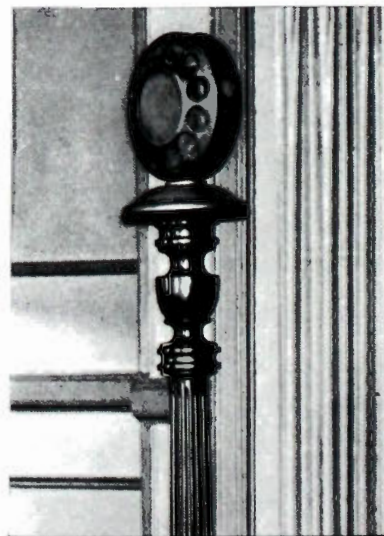

No. 5—The **WEAF** carbon microphone case.



No. 6—The Hanson "Carbon Duo" microphone.

This in turn was replaced by the "tomato can mike," so called because of its appearance, which was the first really successful microphone specially designed for broadcasting. Soon after the "tomato can" came the "Carbon" microphone series with many different mountings, (Lyre, Globe, Duos etc.), later followed by the WEAF "cage" microphone mounted on a floor stand. Incidentally, here was born the common symbol of the broadcasting art, which is now the NBC emblem.

This was followed by the "Hanson" Carbon Duo Stand which represents the first really engineered microphone mounting.



No. 7—The "Bullet" condenser microphone

The object of the ring type of mounting was to allow greater freedom of visibility of the artist or speaker, and to facilitate the then often necessary technical adjustments.

All these early microphones with the exception of the "dish-pan" were of the carbon type, and they were in use when the National Broadcasting Company was formed as the world's first great network system, back in 1926. Two years later came a much greater forward step, when the condenser type microphone was put in use for the first time in the NBC studios at 711 Fifth Avenue. It was known then as the "Bullet Mike" but a year later, in 1929,

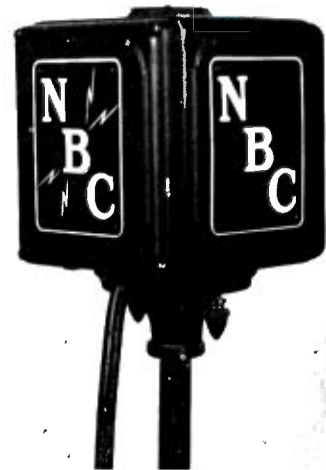

No. 8—The "Camera" condenser microphone.

it was remodeled in design, made more compact, mounted in a square box-like case, and it became known as the "camera mike."

In 1930 there was still another development of importance, this time not in the microphone itself, but in its use. The condenser instrument, for special purposes, was mounted in front of a large parabolic shell, in the concave area of which the mike was centered. This "parabolic" or "reflector" microphone was and still is used for picking up crowd noises in large gatherings, cheering at football games, and speeches from the floor at conventions. It added greatly to the "color" of many "nemo" programs.

(Continued on Page 17)



No. 9—The "Parabola" microphone—an adaptation of the condenser microphone.



No. 10—The "Velocity" microphone, specially designed for high fidelity studio performances.



No. 11—The "Inductor" microphone, specially designed to introduce high quality in remote or outside pickup work.

DID YOU KNOW?

By W. S. FITZPATRICK, RCA Institutes

THAT a scientific magazine suggests that the motion pictures we now see and hear could have scent, which might be arranged through synchronizing a forced draft system so that the odor of an orange grove, for instance, would be wafted through the theatre when an orange grove appears in the picture? No other examples are given but picture fans are mindful that all scenes are not orange groves or rose gardens.

That how the fire fly can radiate "cold light," free from the enormous amount of heat which is present in all man-made sources of light, is a problem which has baffled science for many years, and its solution will revolutionize our lighting industry? (*Scientific American*)

That no radio reception is possible in the vicinity of the famous King Tut-Ank-Kamen's tomb, a fact which natives attribute to the same cause which resulted in deaths of scientists, who made excavations there, but which radio engineers say is caused by hot desert winds saturated with sand, producing ionization effects?

First Place

That Radio City is now conceded to be New York's chief point of interest?

That NBC recently broadcast a musical program from Portland, which commemorated the 50th anniversary of the first public appearance of Paderewski as composer and conductor; the performance taking place in the same hall on the exact hour and day with the same piano used 50 years ago? Paderewski was listening in at Lausanne, Switzerland.

That a new portable public address and sound amplification system for moderate-sized public places, which may be put in operation in less than a minute and which is compactly self-contained in a carrying case and weighing only 28½ pounds, has been introduced by RCA Victor? (*Scientific American*)



W. S. Fitzpatrick, the "Radio Ripley"

That in the automatic equipment used by R.C.A. Communications in its international service, the oscillating pen of the recorder at the receiving end is only one sixty-second of a second behind a transmitter 3000 miles away?

That each of the five transmitters in the two radio stations aboard the S.S. *Normandie* has an independent antenna?

Going Strong

That RCA Victor broadcast transmitter carrying serial number 1 is in use at station WOC at Davenport, Iowa?

That the General Course at RCA Institutes takes a year to complete and furnishes a striking parallel to the initial course of instruction at that school 26 years ago, when all there was to learn about radio could be mastered in a few weeks' time?

That a quarter of a million dollars is being spent in a national Lucky Strike Cigarettes advertising campaign as a tie-in with the Saturday evening broadcasts during August over the NBC-WEAF chain, featuring Fred Astaire and several songs from the forthcoming RKO motion picture, "Top Hat."

That in Switzerland it is proposed to repeat at regular intervals, radio broadcasts which receive good applause, the idea being that, as considerable work is required to build up a program, it is inconsistent that it should be used only once?

That for twelve hours on July 14, last, Rockefeller Plaza, New York, on which the RCA Building fronts, was entirely blocked off from use, such closing of the street being a regular legal procedure proclaiming that, while the street is constantly being used by pedestrians and vehicles, it is still private property?

That by a special process aluminum can be drawn into a wire .0001 inch in diameter and that one pound would reach nearly around the earth?

That radio magazines, issued in the Braille type system for the blind, have made their appearances as a result of the tremendous interest of the blind in radio?

That seventy sons were born to the thirty-one men who have been American Presidents and that twenty of the sons are alive today?

That it's a far cry from sponsoring phonograph records in 1894 to sponsoring NBC programs today, but the analogy is complete, according to George Clark, who quotes from a gramophone company's announcement of that period: "Parties desiring to advertise their wares will find in the gramophone a most valuable medium. We will make for you a special plate, containing, beside a musical piece, a bit of advertising such as you suggest . . . and distribute these gratis to people buying gramophones . . . Nobody will refuse to listen to a fine song even if interrupted by the modest remark 'Wash the baby with Orange Soap'?"

That a survey of NBC's Radio City reception staff revealed that 31 colleges served to educate the 66 men who hail from 36 states and among whom 13 different tongues are spoken?

KVSO — "The Voice of Southern Oklahoma"



Origin of Southern Oklahoma's newest airwave entertainment.

ON Sunday morning at eight o'clock, August 4th, KVSO, the "Voice of Southern Oklahoma", opened its new ultra modern studio. The first day on the air hundreds of calls were received from appreciative listeners, and more than five thousand people visited the studios.

Located on the northern edge of the city limits of Ardmore, at the corner of Chickasaw and Northwest Boulevards, KVSO is housed in a two story white tile stucco building of modernistic Spanish design. The entire broadcasting station, including the power plant, studios, reception room, offices, and living quarters for the operators, is housed in this building.

Two studios will be maintained in the plant. Each has been designed by experts, and each is acoustically correct in every respect. To conform with the outward appearance of the studios, the interior furnishings also carry the modernistic touch.

"Modern in Every Way"

KVSO has been termed by experts who visited the plant prior to its opening as one of the "most modern and up-to-date broadcasting stations for its size in the United States." In quality of

equipment, it is excelled by no station, and is one of the few stations in the southwest to employ true "high fidelity."

The transmitter itself is of the very latest type, manufactured by the RCA Manufacturing Company. It is a 100/250 watt "High Fidelity" transmitter and is a component part of any broadcasting station up to one kilowatt.

Demands of modern high-quality broadcasting are becoming more exacting every day. KVSO's transmitter, however, exceeds the accepted standards in every respect, and the overall performance as a result is markedly superior to that of any other standard low-power transmitter. Other equipment is equally modern. Microphones are of the same design as those used in Radio City.

Monitor speakers will be maintained in each studio, and signal lights will warn the performers when the studio is on or off the air. The programs will be brought to the listeners in the reception room through a large receiving set, located between the doors to the two studios. The reception room will accommodate a score or more of visitors at one time, and easy visibility of the studios will give the guests a first-hand view of the broadcasts as they are in progress.

Efficient Personnel

The control room and the operating of the transmitting equipment will be in the hands of two licensed engineers—H. Franklin Burnett, and Charles M. Dibrell.

Ted Smith, who has had many

(Continued on Page 17)

Below: Looking into one of the very modern studios.



LET'S GET ACQUAINTED



Lewis M. Clement, Appointed Vice President
RCA Victor Engineering, Research

MR. E. T. CUNNINGHAM, President of the RCA Manufacturing Company, announced the appointment of Lewis M. Clement as Vice President in charge of research and engineering for the RCA Victor Division of the Company.

Mr. Clement is one of the most widely known engineering executives in the radio art. He held his first important radio position in 1914, as Assistant Chief Engineer of the Bolinas, California, and Kahuku, Hawaii, transoceanic radio communications stations for the Marconi Wireless Telegraph Company, predecessor of the Radio Corporation of America. Two years later he joined the Bell Telephone Laboratories for whom he supervised the establishment of the first radio-telephone link, between Catalina Island and Los Angeles. During the war he was in charge of the design and development of

all electrical-radio apparatus for use by the U. S. Government services.

In 1925, Mr. Clement became Chief Engineer of the Fada Radio Company, and three years later Vice President and Chief Engineer of the Kolster Radio Company. Following this, he was for a year Assistant Manager of the Radio Department of the Westinghouse Electric and Manufacturing Company, when he became Chief Engineer for radio receivers, for the International Standard Electric Company, the manufacturing organization of the International Telegraph and Telephone Company. His duties in this capacity which he maintained until his new RCA Victor appointment, consisted of engineering the radio receivers for eight foreign factories located in South America, Australia, Budapest, Antwerp, London, Paris and Berlin.

MR. E. T. JONES, formerly of the Western Division, Chicago, is the most recent arrival at "Radio Headquarters."

Mr. Jones for many years has been interested in radio,—in fact, his career began in 1909 when he began working with amateur radio. Following this, he became a ship operator with United Fruit Company, and continued with them until 1914.

From 1919 to 1917, he was with the main plant of WNU (Tropical Radio Telegraph Company), New Orleans, and continued in this position until the declaration of war. He was then transferred to the U. S. Naval Reserve Service as Gunner, Radio Warrant Officer, and was placed in Charge of Underground Installations.

Following his war service, he became connected with Radio News, and edited the first seven editions of this publication. After leaving Radio News, he became Radio Supervisor of the Gulf Division, U. S. Shipping Board, stationed in New Orleans.

In 1921 he formed a connection with the Electrical Supply Company of New Orleans and was made Manager of their Wholesale RCA Radiola Department. He continued in this capacity until 1927, when he became associated with the Victor Talking Machine

(Continued on Page 17)



E. T. JONES



A. R. HOPKINS

THE newest member of the RCA Manufacturing Company to join the Transmitter Sales Section is Alva R. Hopkins, who thus graduates from the Engineering Department of the same company. He has the background that it takes to make a good Transmitter Salesman, having received his B.E.E. degree from Ohio State University in 1926. He actually started his business career while still in college, doing radio research work for the National Carbon Co., on rectifiers and filters under the direction of Prof. C. A. Wright.

After his graduation, Hopkins entered the employ of Day-Fan Electric Co., (which later became the General Motors Radio Corp.) and under the direction of the famous "Boss" Kettering, designed and built production test equipment for radio receivers, becoming assistant in charge of Radio Engineering in 1928.

In 1929, Hopkins joined the RCA organization, at the Van Cortlandt Park, N. Y., laboratories, and soon after was dispatched on an extended tour through the Western States to make a general survey of radio reception conditions and test pre-production receiver samples. Returning, he found activities transferred to Camden, N. J., where he entered the engineering department, undertaking development work successively on "Home Recording" radio-phonograph combinations.

(Continued on Page 17)

W L. LYNDON, who engineers Police Transmitters, was born in Lyndon, Alberta, Canada. He received his primary education at the private school on his father's ranch, and then departed for Montana State College, whence he emerged in 1925 with a degree of Bachelor of Science in Electrical Engineering.

Immediately upon leaving college, he joined the Radio Department of the General Electric Company, and specialized in Antenna Development and Speech Input Equipment. During this period he assisted in the installation of transmitters at CKGW, WENR, and WBT. In 1930 he joined the RCA forces in Camden, heading up the engineering activities on low powered transmitters and speech input equipment. He designed and installed the studio equipment for WCAU, and also took the lead in the Radio City installations in New York City.

It would be a gross error to neglect to say that he attended the Royal Cavalry School in Canada, specializing in small arms and machine guns, and thus not only served in the Canadian contingent during the war, but also with the American forces.

At present he heads the engineering for police radio equipment, including both state and city sectors. He is an associate member of the I. R. E. and also a member of the Sigma Chi, national fraternity.



W. L. LYNDON



V. E. TROUANT

V E. TROUANT, who heads the engineering end of the Broadcast Transmitter Section, including Police and Aviation, is a native of Augusta, Maine. He secured his education at the University of Maine where he graduated in 1921 with the degree of Bachelor of Science in Electrical Engineering.

Shortly after graduation, he joined the Westinghouse organization, specializing in automotive engineering, and remained in this phase of their activities until 1924.

He then entered the radio department which was comparatively new, gaining a comprehensive knowledge of the entire subject. He continued with Westinghouse until 1933.

In that year Mr. Trouant joined the RCA staff in Camden where he became connected with transmitter development, the section which he heads at the present time. He is also an associate member of the I. R. E.

STANLEY GOULDEN HONORED

Stanley Goulden, of the Transmitter Sales Section, was recently notified of his appointment as a member of the Committee of the Telegraph and Telephone Section of the Association of American Railroads.

I. R. E.

The Detroit Convention of I. R. E. was attended by H. C. Vance, B. A. Wilson and Edmund ("Jack") Frost, all of RCA Manufacturing Company's Transmitter Sales Section.

Impedance-Matching Attenuation Networks

By J. B. EPPERSON, Chief Engineer WNOX

IN the study of communication engineering we are constantly reminded of the necessity for matching the impedance of the output circuit to the impedance of the circuit into which it works. When this condition is satisfied, maximum power transfer is obtained and frequency discrimination is reduced to a minimum. The two general methods for matching impedance between communication circuits are 1. The impedance matching transformer and 2. The impedance matching resistance network. For the majority of applications the transformer is more readily adapted. It can be designed to have a satisfactory frequency response with a low power loss. The resistance network, however, has the advantage of being independent of frequency within the range where the resistors employed have negligible frequency characteristics. It has a power loss which is somewhat greater than that of the transformer and which has a definite minimum value for any given impedance matching ratio. This loss, at first thought, seems to be a disadvantage, but there are some instances where impedance equalization and attenuation are desired in the same circuit. In some cases too, it is possible to offset the network loss by an increase of the gain control when used in connection with an amplifier.

When microphones such as the velocity, inductor, and dynamic types are used, it is often an advantage to operate the mixing apparatus at microphone level. This arrangement eliminates the necessity for individual microphone pre-amplifiers and instead allows the use of one pre-amplifier centrally located at the control board.

In the mixer it is essential that the impedance of each input source match the channel input impedance and very desirable that each channel receive approximately the same input level. To fulfill these requirements, it is necessary that the volume level of the incoming remote lines, transcription equip-

ment, and high level microphones where used, be reduced to the proper input level by means of an attenuation network or line pad, and their impedance corrected to that of the mixer input by means of suitably designed impedance matching devices. It is to these and similar applications that the impedance matching attenuation network is particularly adapted. It may be designed for the proper impedance correction and in most cases for the exact required loss.

Figure 1 shows the two types of impedance matching networks which are most frequently employed. Figure 1A represents the "H" or balanced type pad, while Figure 1B represents the "T" or unbalanced type. The two networks are very similar. In the "H" type, the series resistance is divided into two equal parts in order that a balanced line may be obtained. In the "T" type the series resistance is all in one side of the line and thus causes an unbalanced condition.

Either type pad can be used as an impedance matching device or as a straight attenuation network to work between equal impedances. For use in connection with low level mixing apparatus and other applications where the line balance must be maintained, the "H" type should be used. Where a balance line is not an essentiality, the "T" type can be equally as well employed. The resistance constants of the pad depend upon the required loss and the input and output impedance for which the pad is to be designed. When working between equal impedances, the series resistances R1 and R3 are equal.

For determining the constants of the resistance network, simple equations have been derived from fundamental transmission line theory which require the use of hyperbolic trigonometry. It might well be said here, however, that a knowledge of hyperbolic trigonometry is not essential for the correct and effective use of these formulas, it being only necessary

to use hyperbolic function tables to obtain certain values for direct substitution in equations. For use where these tables are not available, or for simplified slide rule calculations, these equations have been re-written into expressions involving the use of logarithms. An approximation is involved in the simplification of the logarithmic formulas, but results which are sufficiently accurate for all practical purposes can be obtained through their use.

The hyperbolic functions primarily employed are Sinh and Tanh (read hyperbolic sine and hyperbolic tangent respectively). They are mathematically defined as follows:

$$\text{Sinh } X = \frac{e^x - e^{-x}}{2} \quad (1)$$

$$\text{Tanh } X = \frac{e^x - e^{-x}}{e^x + e^{-x}} \quad (2)$$

By the use of these two functions, the equations for the solution of the pad resistance constants are expressed as follows:

$$R2 = \frac{\sqrt{Z1 Z2}}{\text{Sinh } X} \quad (3)$$

$$R1 = \frac{1}{2} \frac{Z1}{\text{Tanh } X} - R2 \quad (4)$$

$$R3 = \frac{1}{2} \frac{Z2}{\text{Tanh } X} - R2 \quad (5)$$

Where, R1 = series input resistance

R3 = series output resistance

R2 = shunt resistance

Z1 = source impedance

Z2 = load impedance

X = .115 (required pad loss in DB)

By solving for Z1 and Z2 in (4) and (5) above, we obtain the expressions:

$$Z1 = \text{Tanh } X (R2 + 2R1) \quad (6)$$

$$Z2 = \text{Tanh } X (R2 + 2R3) \quad (7)$$

Equations (6) and (7) may be used as an accurate check for the impedances Z_1 and Z_2 , where the resistance values and loss are known.

With reference to (4) and (5), it is seen that where R_2 becomes equal to or greater than the expression $Z_1/\text{Tanh } X$, or $Z_2/\text{Tanh } X$, R_1 or R_3 either become equal to zero or equal to a negative quantity. Since the negative resistance is impossible, there is a minimum loss which is consistent with any impedance matching ratio, and this minimum value is reached when R_1 or R_3 becomes equal to zero. This minimum loss is given by the expression:

$$8.68 (\text{Cosh}^{-1} \sqrt{Z_1/Z_2}) \quad (8)$$

The table in Figure 2 is worked out from this expression and gives the minimum insertion loss for the most frequently used impedance matching ratios.

For all practical network design, $e^{-\alpha}$ in (1) may be dropped, and $\text{Sinh } X$ assumed to equal $\frac{1}{2}(e^X)$. Then, in terms of logarithms,

$$\text{Sinh } X = \frac{1}{2} [\text{anti-log } X(.4342)]$$

and by means of the function relation:

$$\text{Tanh } X = \frac{\text{Sinh } X}{\sqrt{1 + \sin^2 X}}$$

and,

$$\text{Tanh } X = \frac{K}{\sqrt{1 + K^2}}$$

where $X = \frac{1}{2} \text{anti-log } X(.4342)$

With this analysis, we can rewrite (3), (4) and (5) into logarithmic equations as follows:

$$R_2 = \frac{\sqrt{Z_1 Z_2}}{K} \quad (9)$$

$$R_1 = \frac{1}{2} Z_1 \frac{\sqrt{1 + K^2}}{K} - R_2 \quad (10)$$

$$R_3 = \frac{1}{2} Z_2 \frac{\sqrt{1 + K^2}}{K} - R_2 \quad (11)$$

Where $X = .115$ (required pad loss in DB)

$$K = \frac{1}{2} \text{anti-log } X(.4342)$$

Illustrations

By the formulas (3), (4) and (5), let us determine the constants for a 500-200 ohm impedance matching network to have an attenuation factor of 20 DB.

From figure 2, we find the minimum insertion loss for the ratio 500/200 (2.5) to be 8.9 DB. Since DB is well above the minimum we know that it is possible to design a pad having this loss, so we may proceed with the calculation.

First, we find X equal to (.115 X 20) equals 2.3. It is given that Z_1 equals 500 (input impedance), and Z_2 equals 200 (output impedance).

From a hyperbolic function table, we find $\text{Sinh } X$ to be 4.93 and $\text{Tanh } X$ to be .98.

Substituting the above values in (3), (4) and (5), we obtain:

$$R_2 = \frac{\sqrt{(500)(200)}}{4.93}$$

$$= 64 \text{ ohms}$$

$$R_1 = \frac{1}{2} \frac{500}{.98} - 64$$

$$= 223.1 \text{ ohms}$$

$$R_3 = \frac{1}{2} \frac{200}{.98} - 64$$

$$= 70 \text{ ohms.}$$

If desired, the resistor values found above may be checked by substituting in (6) and (7) to see if they equal approximately the original values of Z_1 and Z_2 . Thus:

$$Z_1 = .98(64 + 446.2) = 449.9$$

$$Z_2 = .98(64 + 140) = 199.9$$

This check is merely an inversion of the original work.

For the logarithmic solution of the same problem, we make use of formulas (9), (10), and (11).

As in the example above, X equals (.115 X 20) equals 2.3. K equals $\frac{1}{2} \text{anti-log } 2.3(.4342)$ equals $\frac{1}{2} \text{anti-log } .996$ equals 4.94.

Therefore:

$$R_2 = \frac{\sqrt{Z_1 Z_2}}{4.94} = 64 \text{ ohms}$$

$$R_1 = \frac{1}{2} 500 \frac{\sqrt{1 + (4.94)^2}}{4.94}$$

$$- 64 = 223 \text{ ohms}$$

$$R_3 = \frac{1}{2} 200 \frac{\sqrt{1 + (4.94)^2}}{4.94}$$

$$- 64 = 70 \text{ ohms}$$

The accompanying impedance matching chart has been worked out by the expressions (3), (4) and (5), and gives the values of R_1 , R_2 , and R_3 sufficiently accurate for practical networks to work between given impedance and loss values. The values given apply to the "H" pad, it being necessary to double R_1 and R_3 where a "T" pad is to be used. The minimum insertion loss is given for each impedance combination, and represents the minimum loss for which that particular pad may be designed. The first column which lists resistance values for pads to work between two 500 ohm impedances may also be used for determining resistance values for pads to work between any two equal impedances. For two equal impedances other than 500 ohms, it is only necessary to find from the table the 500 ohm values for the desired loss, and multiply these values by the factor $Z/500$. For instance, a 50-50 ohm pad having a loss of 20 DB is desired. From the table it is found that for a loss of 20 DB, the 500 ohm values are: R_1 , R_3 equals 204.5 ohms, and R_2 equals 101 ohms. Multiplying these values by $Z/500$ (50/500 in this case) or .1, we find R_1 , R_3 equals 20.4 ohms and R_2 equals 10.1 ohms, the values for the 50-50 ohm 20 DB pad.

The 500-500, 500-200, 500-50, and 200-50 ohm values for R_1 , R_2 , and R_3 can be read directly from the table. A 500-50 ohm pad may be inverted and used for a 50-500 ohm pad etc., so that the values given may be

(Continued on Page 23)

NEW HOME FOR KSD

ROBERT L. COE, Chief Engineer, KSD

ON February 13, 1935, KSD, one of the pioneer stations of the country, began broadcasting from its new studios.

The studios are located in the Post-Dispatch Building, on the roof of which the KSD transmitter is located. Space available for the construction of additional studios while rather limited, was fortunately, practically two stories in height, allowing the use of high ceilings and permitting the construction of an observation gallery and offices on the mezzanine floor.

The area was sufficient for two studios of such size as to accommodate any ordinary production and together with the old KSD studio, which is being entirely redecorated and refinished, provide adequate facilities for local program production.

On account of the presence of considerable vibration in the Post-Dispatch Building due to a large amount of heavy machinery, presses, etc., and also due to the fact that the studios are located on the ground floor of the building, immediately adjacent to one of the City's main thoroughfares, adequate sound insulation was quite a problem. The studio floors are hung on springs, entirely independent of the building and the studio walls. The space between the joists is filled with ground cork. Walls and ceiling of the studio are covered with a perforated metal sheeting behind which is placed a rock wool blanket to provide necessary absorption.

In selecting and laying out the speech input equipment for the new studios, every effort was made to provide high fidelity performance from microphone to monitoring loud speakers and to the line feeding the transmitter.

Each studio is provided with its own control room equipped with a complete audio channel feeding directly to the transmitter. The control room for Studio "A" acts as more or less of a master control room in which are located line

terminating panels, monitoring amplifiers and loud speaker switching facilities. The individual studio bays include three 41-B preamplifiers, a 40-C program amplifier, and a 4194-B monitoring amplifier.

All equipment, including microphone lines, is terminated on jacks to give maximum flexibility. The control console has a master gain control and "on" and "off" buttons for each channel, with indicating lights. The output of the 40-C is fed to the transmitter line

through a line relay, also controlled by "on" and "off" push buttons on the console. A locking key is provided on the console so that when in a locked position with one studio on the line, it is impossible to close the line relays in either of the other two studios. When in the "off" position, the line relay "on" button disconnects either of the other studios that might be on the line and closes the line relay controlled by that button. An additional key is pro-

(Continued on Page 17)



Corner of the control room at KSD showing RCA equipment in position

WIOD

"The Good Will Station of The Caribbean Empire"



View of the control room

mounted the RCA program amplifiers, velocity microphone preamplifiers, patching panels and three monitoring amplifiers. The monitoring amplifiers feed RCA Victor High Fidelity speakers in the main studio, the second studio, the audition balcony, the main control room and auxiliary control room. The auxiliary control room, adjoining the main control room, has a third panel which is interlocked with the two control panels in the main control room. With this arrangement it is possible to audition a program in the second studio, while a program is in progress in the main studio.

A new and modern air conditioning system is also housed in the north wing, permitting a constant temperature of 78 degrees to be maintained in the large and small studios, balcony, control room and auxiliary control room.

The studios in general appearance somewhat resemble the studios of Radio City. Their type of construction is very similar, incorporating the spring clip system. There are double wall sections around the studios, steel panels

(Continued on Page 23)

LOCATED in the Miami Daily News Building, which is recognized as one of the finest pieces of architecture in the community, the studios of WIOD consist of a large studio, 38 feet by 38 feet, a second studio, 24 feet by 18 feet, and an audience balcony overlooking the main studio.

Situated on famous Biscayne Boulevard in Miami, the structure housing the main studios is built of structural steel and reaches 38 feet to the gabled roof. The gravelled roof of this structure incorporates huge call letters of WIOD, made up of different colored rock. This forms one of the most conspicuous aerial signs in Miami. At night, high up on the four sides of the News Tower may be seen the illuminated call letters of WIOD, alternating with the letters: NEWS.

There are two wings built on either side of the studio structure—the south wing comprising a large organ loft, housing a Wurlitzer pipe organ and an artists' room, the north wing of the building accommodating the technical division of the studios. The control room, a wedge-shaped ele-

vated chamber with observation windows at 45 degree angles in the corner of each studio, from which the operator has an unobstructed view of both studios, houses a complete two-channel RCA Victor Speech Input equipment. Three relay racks are used in the assembly on which are



A corner in one of the studios

New Vertical Radiator at WDOD

RADIO station WDOD in Chatanooga, Tenn., boasts a new half-wave vertical radiator recently built by the Truscon Steel Company of Youngstown, Ohio.

The results obtained with this new installation are reported as very gratifying. For the field intensity measurements show that the efficiency of this new antenna system is approximately twice that of their old antenna. Station WDOD formerly had a single-wire T-type antenna suspended between two 110-foot wooden poles, one of which can be seen in the background of the tower picture.

During a recent visit of Benjamin Adler, of the Transmitter Section of the RCA Manufacturing Co., Inc., his picture was taken in some very prominent company. Beginning at the left in this picture are M. Eager, Engi-

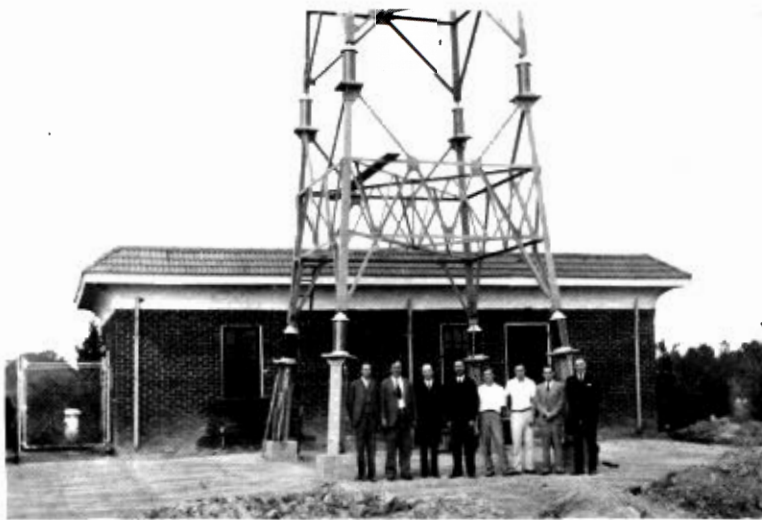

Group of notables outside the **WDOD** transmitter building (see text)

neer for Glenn D. Gillett, who appears next; H. W. Grahl, District Manager of the Truscon Steel Company; E. W. Winger, Vice President of WDOD; two members of the staff; Ben Adler (himself), and Norman A. Thomas,

President of WDOD.

Station WDOD has recently installed new RCA Victor studio amplifier, transcription turntable and microphone equipment, in line with the general improvement policy.

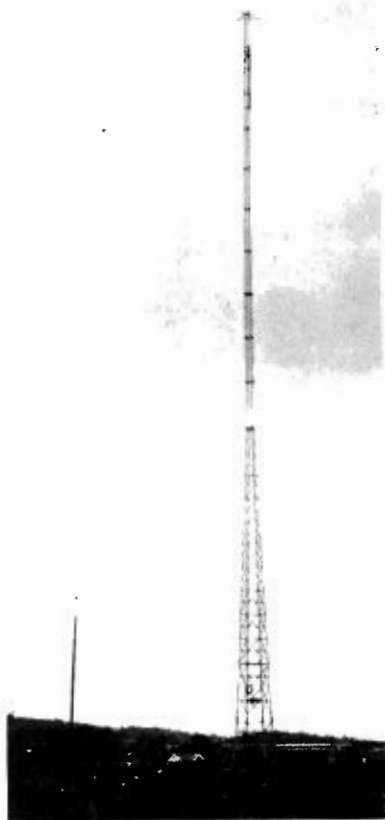

The new half-wave vertical radiator at **WDOD**

WBEN Puts Curves on Air

WISHING to take frequency characteristics of the transmitter and speech equipment, WBEN in Buffalo utilized this as an opportunity to put on a unique program. R. J. Kingsley, Technical Director, secured permission from the supervisor of radio to broadcast the tests late on the evening of February 8th. Explaining that the station was to be modulated with varying tones, the announcer advised that listeners could calibrate their receiving sets and see how wide a band they could receive. Each tone was named as put on and in addition illustrations were given of the tones in various instruments of an orchestra and the importance of being able to receive the entire audible band was brought out.

The station received hundreds of telephone calls from interested listeners as well as many letters. Radio service men used the opportunity to check equipment and to calibrate apparatus.

An over-all curve was taken on WBEN from microphone terminals to the antenna. This curve has been combined with a velocity microphone curve to give the data on the station, including microphone, studio, amplifiers, telephone line to transmitter, and transmitter itself. A considerable amount of work has been done by Messrs. Kingsley and Horn to produce a flat characteristic on a 15-mile line.

WBEN uses an RCA 1-B transmitter and RCA speech input equipment throughout.

WBT Adds Vertical Radiator to RCA Transmitter

By WILLIAM A. SCHUDT, Jr., General Manager, WBT

WBT, Southern Key Station of the Columbia Broadcasting System, in Charlotte, N. C., has a new and much stronger voice since the addition of a 435-foot vertical radiator to its modern 50,000 watt transmitter.

With the completion of WBT's new vertical radiator, the tallest man-made structure in the Carolinas, Charlotte's big 50,000-watt broadcasting station is now one of the most modern in the entire world.

With this new radiator giving WBT practically the equivalent of an increase of power to 100,000 watts, it is interesting to note that there is only one station in the United States with more power than WBT.

The new vertical radiator which was officially put into use December 19th, is a steel tower rising 435 feet in the air and balanced on a 10-inch insulator. The tower is held in place by four guy wires connected to its superstructure at approximately one-third its height. From its 10-inch base insulator, the tower rises to a width of 17 feet in its middle section, and tapers off to one foot in diameter at the top. It is not a mast for an antenna, it is the antenna itself radiating from each part of its 200 tons of steel the full volume of WBT's 50,000-watt transmitter.

Today, there are only fourteen vertical radiators in use throughout the entire world. Charlotte, N. C., has followed the example of New York, Philadelphia, Boston and Budapest, Hungary, in placing in use this, the most modern type transmitter radiator.

This is the latest chapter in a fast-moving panorama of success. WBT was the first station in the South, beginning its broadcasting on April 7, 1921, when only 250 watts of power carried its programs to a limited audience. From then on, progress was rapid and

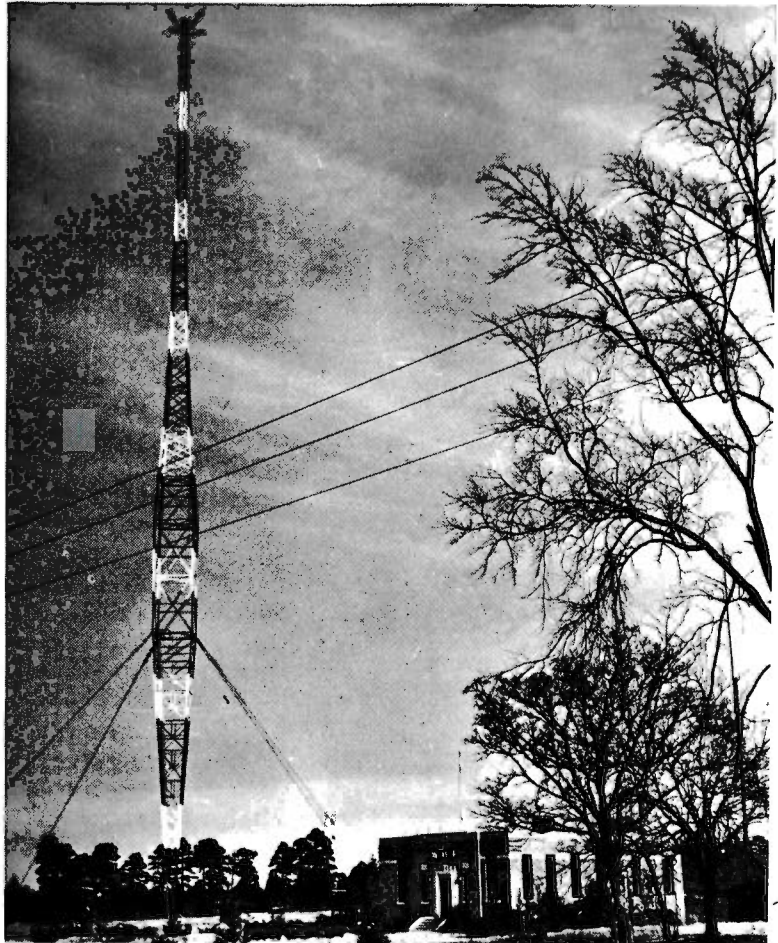

The New Vertical Radiator installed at Station **WBT**, Charlotte, N. C.
This tower is 435 feet high

the station grew in power and popularity from year to year. A little over a year ago, December 13, 1933, WBT installed its new 50,000-watt transmitter ten miles southeast of Charlotte, and on December 19, 1934, exactly one year and six days later, it added the revolutionary vertical radiator to its equally modern equipment.

As WBT now goes on the air, its power has been multiplied two-hundredfold over that employed in 1921. Utilizing the nationally cleared channel of 1080 kilocycles, WBT's powerful voice now not only penetrates every city and town in the United States but is

received consistently and strongly in such far-away places as Australia, New Zealand, England, France, Holland, Germany, South America, and, of course Canada and Mexico. Following the all-night broadcast marking the first full day of operation with the new vertical radiator, WBT received hundreds of wires, letters and phone calls from all parts of the world, commenting on the increased strength with which that station's programs were received. Even before the all-night program had ended cables had been received from England, Hawaii, and also

(Continued on Page 17)

Pointed Facts About Transcription Needles

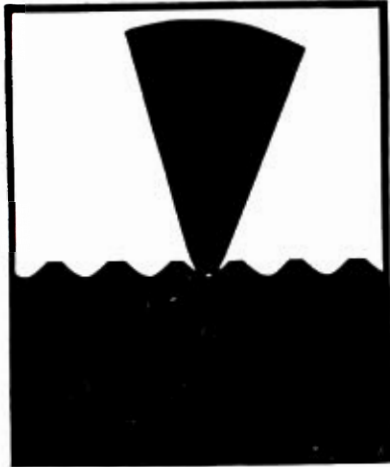

Needle A of satisfactory dimensions in standard record groove before playing.

ARGELY because of the greatly improved recording that is being done today, electrical transcriptions have gained a much wider acceptance by the broadcasting stations throughout the country, than formerly. The large advertisers are insisting on the highest quality of recording and are sparing no expense to get the best results. They realize that transcriptions must compare favorably with live broadcasts in order to hold the listening audiences, which, of course is the real aim of both the advertiser and the broadcasting station.

Needle A after playing a 16-inch record. (Note worn shoulder on groove.)

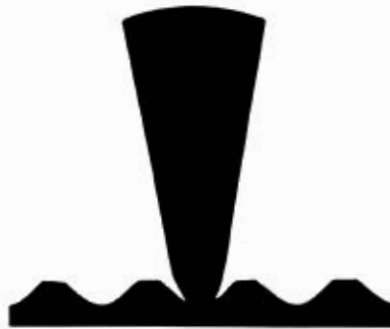
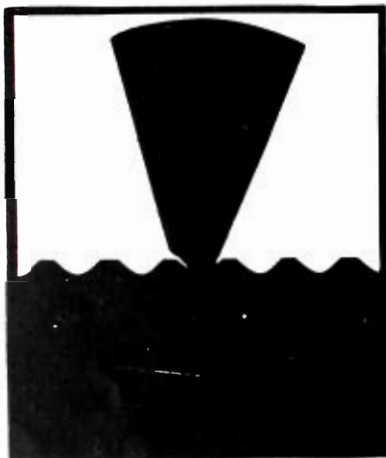

Victor needle in standard record groove playing.

Many times it is the apparently unimportant detail that is responsible for defective performance, and this is often the case in the reproduction of electrical transcriptions. The greatest care should be taken in choosing the needle that is used in reproduction and to fill these needs of the radio stations, the RCA Manufacturing Company recommends the use of the 100% Shadowgraphed needle.

We have developed a method of inspection that assures a uniform, accurate point. Before the needles leave the factory they are first examined for quality and durability. Following this test the needles are shadowgraphed, which means simply this: A painting of a perfect needle magnified 65 times its actual size is placed before a powerful

The Victor needle after playing a 16-inch record.

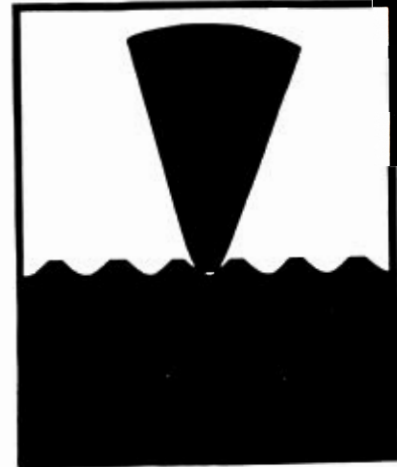
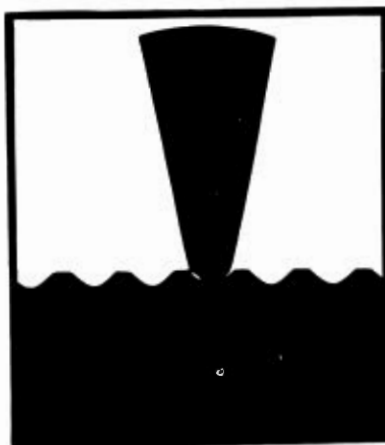

Needle B in standard record groove before playing. (Note the unsatisfactory fit.)

projection machine. The needles to be inspected are run slowly through the machine which magnifies them 65 times their actual diameters. The magnified image of the needle falls upon the painting of the perfect point and it must coincide with it in every particular. If the needle is even minutely defective, it is at once discarded. This unique method of operation insures 100% performance.

In the manufacture of a Victor needle every phase of its purpose has been studied. It is constructed to search out all the sound vibra-

Needle B after playing a 16-inch record. (The shoulders on both sides wearing on the walls.)

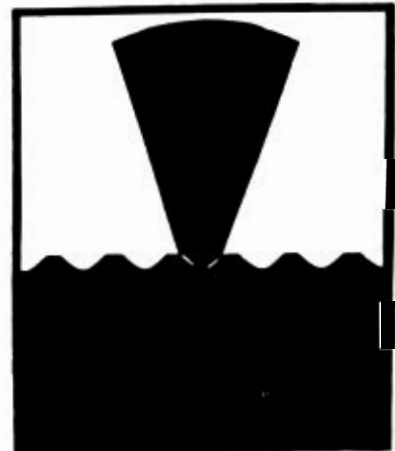

TRANSCRIPTION NEEDLES

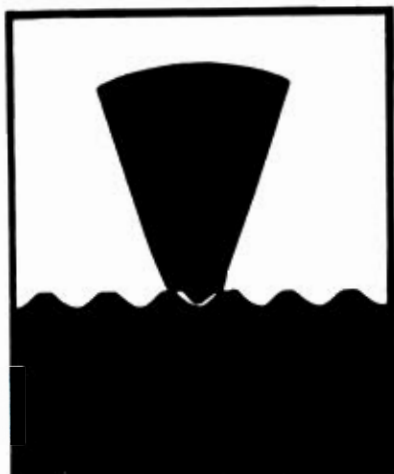

Needle C after playing a 16-inch record. (Emphasized shoulders wearing on both walls.)

tions concealed in the grooves of a record, to give every nuance of the music which the artists have engraved there, and at the same time not damage the delicate walls of those grooves.

It is this extreme care practiced in the manufacture of a comparatively minor detail that assures perfection of reproduction and at the same time, listener satisfaction.

Needle C in standard groove before playing. (Note that needle rides the walls.)

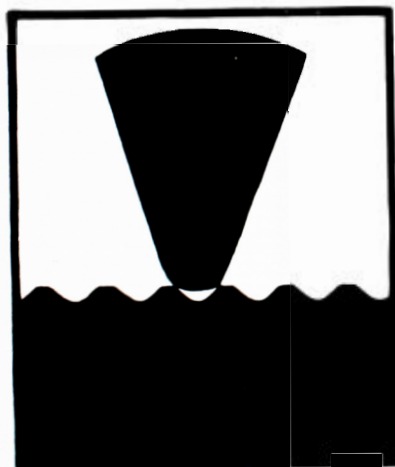

W B T

(Continued from Page 15)

from the Northwestern part of Saskatchewan, to say nothing of the countless wires pouring in throughout the night from the West Coast and practically every state in the Union.

MICROPHONE PROGRESS

(Continued from Page 5)

The condenser mike was standard equipment for three years,—a long period in the history of the microphone. Then in 1933, when NBC moved into its great Radio City headquarters, the velocity (ribbon) mike was introduced for the first time,—an important contribution to the broadcasting art made by RCA Victor engineers.

Another RCA Victor development, which has just been brought into use, is the new "50-A" Inductor Microphone. This new device is now being put into service by NBC on all "nemo" programs,—those originating outside the studios. The chief improvements it embodies are reduction of inherent electrical noise, and increased convenience in moving the instrument about, because of its small size and light weight.

With the "Velocity" Mike in use in the studios, and the 50-A "Inductor" Mike in the field, NBC is now equipped with the latest developments in microphone facilities, which deliver a program quality quite undreamed of, when the network was formed eight years ago.

What the next step may be, (and there surely will be a next step in this constant improvement,) the engineers are unable to say. But perhaps it's just around that famous corner. The research and development men are always hard at work.

A. R. HOPKINS

(Continued from Page 9)

centralized radio equipment, public address equipment, police and navy radio equipment and broadcast transmitters and speech input equipment.

In this new field of activities, Hopkins is handling the sales of Speech Input Equipment for broadcast stations (under I. R. Baker) and also Police Radio Equipment, assisting P. A. Anderson in this latter activity.

He was elected to Eta Kappa Nu and Sigma Xi while "in school," and is also an Associate Member of A.I.E.E. and a member of I.R.E.

E. T. JONES

(Continued from Page 8)

Company as Assistant District Sales Manager, of the Southeastern District. In 1929 he was recalled by the Electrical Supply Company to manage their Wholesale Electrical Refrigeration and Radio Division. His work was so outstanding in this position that he was called by the RCA Manufacturing Company to become Western Division Sales Promotion Manager, RCA Radiotron Division, in Chicago.

During the whole period of his association with the electrical and radio industry, Mr. Jones has invented many devices which have aided in very definite advances. He has also written many articles which have appeared in technical publications, and has been a member of the I.R.E. for many years. In his new position, Mr. Jones will have charge of Advertising and Sales Promotion for the Engineering Products and Telephone Divisions.

KVSO

(Continued from Page 7)

years of experience in the radio field, comes to Ardmore to become station director and commercial man. He will also act in the capacity of chief announcer, and his pleasing voice will be heard frequently over KVSO.

Program direction will be in the hands of Weldon Wallace, another Ardmore man, who will find his hands well filled in meeting the demands of the station programs every day. His voice, too, will be heard over the station regularly.

KSD

(Continued from Page 12)

vided which, when operated, disconnects control room loud speaker, connects the studio loud speaker, opens all the studio microphone channels and connects the control room microphone to one of the pre-amplifiers. This provides a very satisfactory talk-back and can also be used in an emergency for making station announcements.

Each control room and studio is supplied with a UZ-4209 loud speaker fed from the 4194 amplifier in the control room. A key on the control console permits the

(Continued on Page 23)

General Considerations of Tower Antennas for Broadcast Use

By Dr. G. H. BROWN and H. E. GIHRING, RCA Engineers

This is the third installment of the paper prepared for and copyrighted by "Proceeding of the Institute of Radio Engineers." It is being published by permission as a serial.



Dr. G. R. Brown, RCA Mfg. Co.

The results are shown by the lower row of vectors shown in Fig. 27. We see that as we proceed from the base of the antenna, the earth current advances in phase and decreases in magnitude and then starts a phase lag and increases in magnitude. These vectors were computed on the basis of one ampere into the base of the antenna. This value of current was chosen so that one can easily see the relative magnitudes of current. A similar set of vectors was computed using the antenna current distribution on a type A tower which is 215 electrical degrees tall. This antenna current distribution is given by curve B, Fig. 4. The earth currents were necessarily computed by a graphical method. The results are shown by the upper row of vectors of Fig. 27. We see that in this case the earth current immediately begins to lag and increase in magnitude as we proceed from the antenna. The magnitude of the vectors is plotted for both cases in Fig. 28. If we could measure the earth current at various distances from the antenna, we could easily

tell whether the current on the antenna had a complete phase reversal or not.

Actually we can measure this current in a rather simple fashion. It has been shown that the flux density in space at the surface of the earth is related to the total earth current by the relation

$$2\pi xB = \mu I_x$$

where x is the radius of the cylinder shown in Fig. 22 (centimeters), I_x is the total earth current flowing through the surface of the cylinder (amperes), B is the electromagnetic flux density at a point on the surface of the earth x centimeters from the antenna base, (webers per square centimeter), and μ is the permeability of free space ($4\pi \times 10^{-9}$). It is of course assumed that the earth current is distributed uniformly around the periphery of the cylinder. The measurement of flux density can be made with a loop antenna and a calibrated vacuum tube voltmeter. The loop is untuned so that the vacuum tube voltmeter reads the induced voltage. The induced voltage is related to the electromagnetic flux density by*

$$e_i = 2\pi f N A B$$

where,

f = frequency (cycles per second)

N = number of turns on the loop

A = area of the loop (square centimeters)

B = electromagnetic flux density (webers per square centimeters)

e_i = induced loop voltage (volts)

*Appendix B, equation (16).



H. E. Gihring, RCA Mfg. Co.

Combining (6) and (7),

$$I_x = \frac{2\pi x e_i}{\mu 2\pi f N A} = \frac{x e_i}{60 h}, \quad (8)$$

where $h = 2\pi f N A / c$ is the effective height of the loop measured in centimeters, and c is the velocity of propagation of light (3×10^{10} centimeters per second).

If x is measured in meters, (8) becomes

$$I_x = \frac{x e_i}{0.60 h}, \quad (9)$$

If x is measured in feet, (8) is

$$I_x = \frac{x e_i}{1.97 h}, \quad (10)$$

where h is still expressed in centimeters.

Thus we have a simple method of measuring the earth currents in the vicinity of an antenna. We simply proceed along a radial line measuring the distance from the antenna and reading the vacuum tube voltmeter. Since some antenna effect may exist, it is desirable to reverse the loop at each point and take the average of the

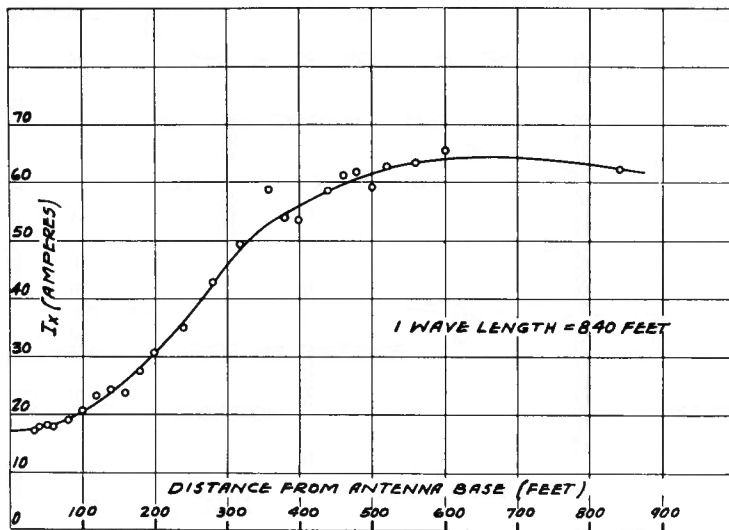

Figure 29

a radial wire, and compare it with actual tests. Chamberlain and Lodge* give measurements of current in a single radial wire which is part of the ground system of a vertical radiator. Fig. 6 of their paper is here reproduced as the lower half of Fig. 31. Their measurements were made at both WSM and WABC. The towers were both 0.6 wave lengths tall, and in both cases the ground system consisted of 60 radial wires. Practically the only difference in the installations was the conductivity of the soil. The soil at WSM was of high conductivity and that at WABC was low conductivity.

To calculate the current in the wires, given the total earth current, I_x , we merely multiply by the ratio I_w/I_x which is given in Figs. 21 to 23. We will use the measured value of earth current at WCAU as I_x . The ratio above mentioned will be taken from Figs. 22 and 25 for the case of 60 radial wires. The result is shown in the upper part of Fig. 31. There is quite a good agreement with the experimental result of Chamberlain and Lodge.

VII. Conclusion

Vertical radiators with varying cross section along the tower depart considerably in their performance from the theoretical antenna with sinusoidal current distribution. The effect on the ground

wave for the type A tower is shown in Fig. 16, (compare curves A and C) and the effect on radiation at vertical angles is shown on Figs. 12 and 14.

It was possible from current distributions obtained on model antennas to calculate the values corresponding to curve A, Fig. 16, which are shown on the figure and are in good agreement. It was also possible by methods described to calculate the vertical pattern shown on Fig. 12. Calculated and measured values are in good agreement.

The departure of the type B antenna from theoretical values is shown by curve B, Fig. 16. No vertical patterns were obtained by actual airplane measurements on

the type B antenna. However, the actual agreement obtained in the case of the WCAU antenna (type A) substantiates the method of attack.

The present tower antennas on the whole are unsatisfactory compared to what may be obtained. The cause of the discrepancy lies in the varying cross section of these towers which causes the current distribution to be nonsinusoidal. Experiments on models from which the current distribution was obtained for type A and B towers show that sinusoidal distribution is again approached when the cross section is made uniform. In the case of a single wire, the distribution is sinusoidal as shown in Fig. 11.

The effect of nonsinusoidal distribution in the cases mentioned is highly detrimental since the horizontal radiation is less and the skyward radiation more than for sinusoidal distributions, which exactly counteracts the effect that was sought in the use of such radiators. Hence, in order to approach the theoretical values for sinusoidal distribution, it is necessary to have a sinusoidal distribution of current on the tower which, as shown by the model experiments, can be obtained only by a tower of uniform cross section. Other expedients such as capacity crowns help slightly, as shown in Figs. 9 and 10, but there are further reasons for making the distribution absolutely sinusoidal.

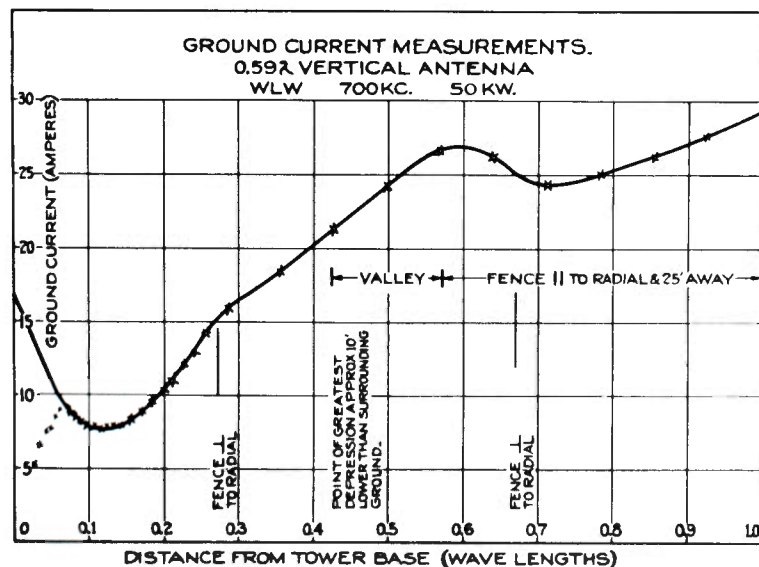

Figure 30

* A. B. Chamberlain and William B. Lodge, "The Broadcast Antenna," Proc. of the Radio Club of America, Vol. 11, No. 8, Nov., 1934, Fig. 8, p. 55.

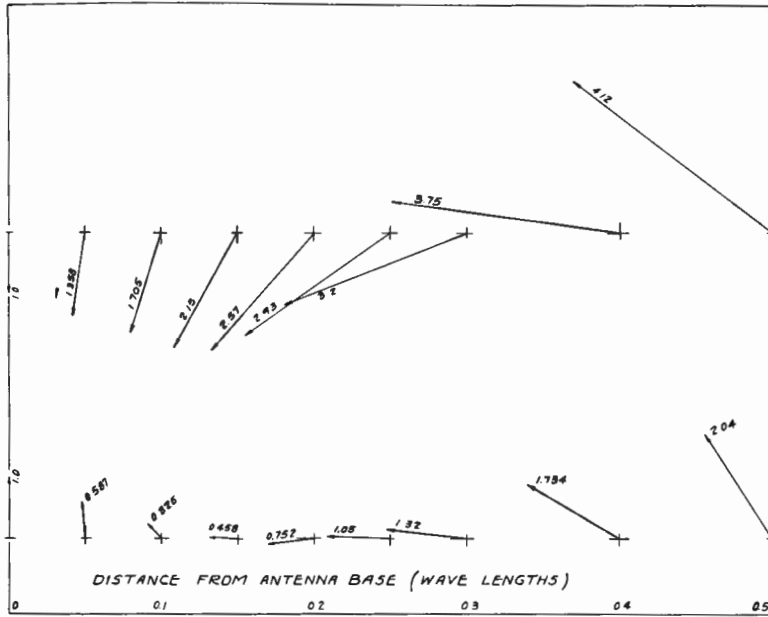

Figure 27

two readings. Where the ground around the antenna is fairly flat, such a measurement should be of value in determining whether or not the current distribution on the antenna is close to sinusoidal. Such a procedure was carried out in the vicinity of the WCAU antenna, which is a type A tower of height 215 electrical degrees and is the case for which the calculations of Fig 27 were made. Since the ground was rather rough, the average of a number of readings was taken. The results are shown in Fig. 29. The earth current rises quickly to over sixty amperes at a little beyond one-half wavelength, (420 feet). It has dropped slightly at one wavelength distant from the antenna, (840 feet).

A measurement at one mile (6.28 wavelengths) showed that attenuation of the earth had dropped the earth current to 43.2 amperes. These measurements show no tendency to have a dip as predicted for a sinusoidal distribution. and check rather well with the theoretical results arrived at from our tests with the models. It should be noticed that the curve when extrapolated to zero abscissa indicated an antenna current of 17.3 amperes at 50,000 watts. The antenna current meter actually indicated 22.7 amperes. This apparent discrepancy is easily accounted for. The measured antenna resistance with all the light-

ing apparatus, etc., tied on is 97.0 ohms. Then the input power is $I^2R=22.7^2 \times 97.0=50,000$ watts. The resistance measured before any equipment was attached was 165.0 ohms. This is closer to the true antenna resistance. The true antenna current as shown by Fig. 29 is 17.3 amperes. Then the input power to the antenna proper is $17.3^2 \times 165.0 = 49,300$ watts. Thus we see that the true antenna current is masked by the capacity at the base of the antenna. This effect is more completely discussed in Appendix C.

A similar measurement of earth current was made at WLW, lo-

cated at Cincinnati, Ohio. This tower is much more needle like in shape than is the WCAU tower. Consequently, we might expect the antenna current distribution to be more nearly sinusoidal. The measured earth current is shown in Fig. 30. We see that the earth current passes through a very distinct minimum in the neighborhood of one-tenth wave length from the base of the antenna.* Other observations made by the staff of WLW indicate that the vertical radiation characteristic is close to that which would be obtained if the antenna current distribution were exactly sinusoidal. The experimental points shown on Fig. 30 depart from the smooth curve rather abruptly when the distance from the antenna base is less than 0.06 wave lengths. This is perhaps due to overloading of the measuring set. The measurements at WLW were made with a conventional field intensity measuring set.

We have determined the magnitude of the total earth current and the ratio of the current in the radial wires to the total earth current. The total earth current is made up of the two components, I_w , the current flowing in the radial wires, and I_e , the current actually flowing in the earth. It is interesting to calculate the current which we might expect in

* These data were furnished by Mr. J. A. Chambers, Technical Supervisor of Stations WSAI-WLW.

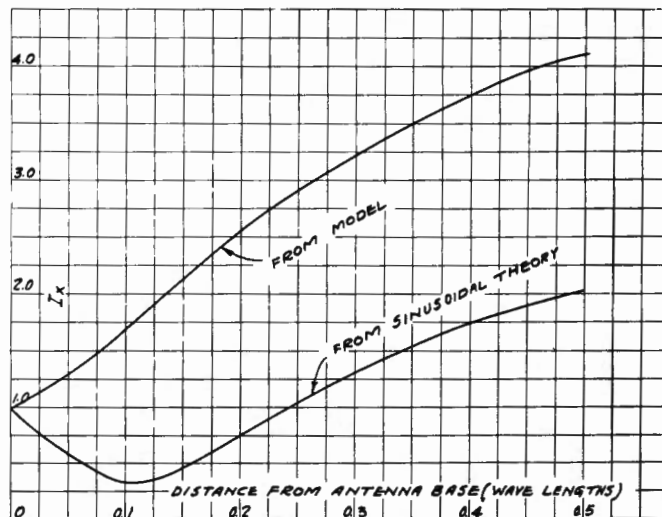

Figure 28

The chief limitation on the primary night service area for cleared channel stations having sufficient power to lay down a serviceable signal from 60 to 100 miles is fading. In order to extend the service area, the fading zone must be located further from the transmitter. This can be accomplished only by reducing the sky-wave radiation. Since it is expensive to experiment with radio antennas at broadcast frequencies, it is necessary to be able to predict what will happen before the antenna is built. Such predictions can only be accurately made when the designer is assured of sinusoidal distribution, which in turn means that the tower must be of uniform cross section.

The most important phase of antenna design is sky-wave elimination since this is apparently the most serious limitation of the night service area. The increase in ground-wave signal is important but must be sacrificed for sky-wave elimination.

The optimum electrical length of 230 degrees, which gives a theoretical 41 percent increase in horizontal radiation as compared to a 90-degree antenna, would cause very serious fading. Hence, 190-degree antennas are now used, giving a 27 per cent increase in ground wave as compared to a 90-degree antenna. A 190-degree antenna with sinusoidal distribution will increase the distance to the fading zone considerably.

It is desirable to have some quantitative guide as to what effect a change in the output of the antenna has on the day service radius. In van der Pol's discussion of the Sommerfeld propagation theory, * it is pointed out that for a numerical distance of more than twenty the field strength drops off very nearly as the inverse square of the distance. Under average conditions in the broadcast band, the numerical distance is more than twenty at the edge of the service area, so that in this zone, the service radius may be said to vary as the square root of the magnitude of the field intensity measured a few wave-

lengths from the antenna. Hence, the use of a 190 degree antenna instead of a 215 degree antenna will give a service radius of $\sqrt{1.27/1.39}$ or 96 per cent of that obtained with a 215-degree antenna. On the other hand, the service radius of a 190-degree antenna is $\sqrt{1.27/1} = 1.13$ times greater than that of a 90-degree antenna, or an increase of 13 per cent. Even the 230-degree antenna which gives the greatest intensity along the ground yields an increase in service radius as compared to a 90-degree antenna of only 19 per cent.

The above is given in an attempt to show that the increase in service radius is not so much the important factor in these antennas

as the reduction in sky wave. In the broadcast band, the optimum antenna for the reduction of sky wave at distances from 60 to 120 miles is the 190 degree antenna.

The present practice in the use of ground systems is to have too few radials of insufficient length. Since for antennas of 180 degrees and over, the maximum loss occurs in the vicinity of 0.35λ from the antenna, the ground system should at least extend beyond this point, preferably to 0.5λ . The effect of not using enough radials is shown on Fig. 25. If a small number of radials are used, the ratio of the current in the wires to the total ground current drops rapidly, thus increasing the losses. At broadcast frequencies, for aver-

Figure 31

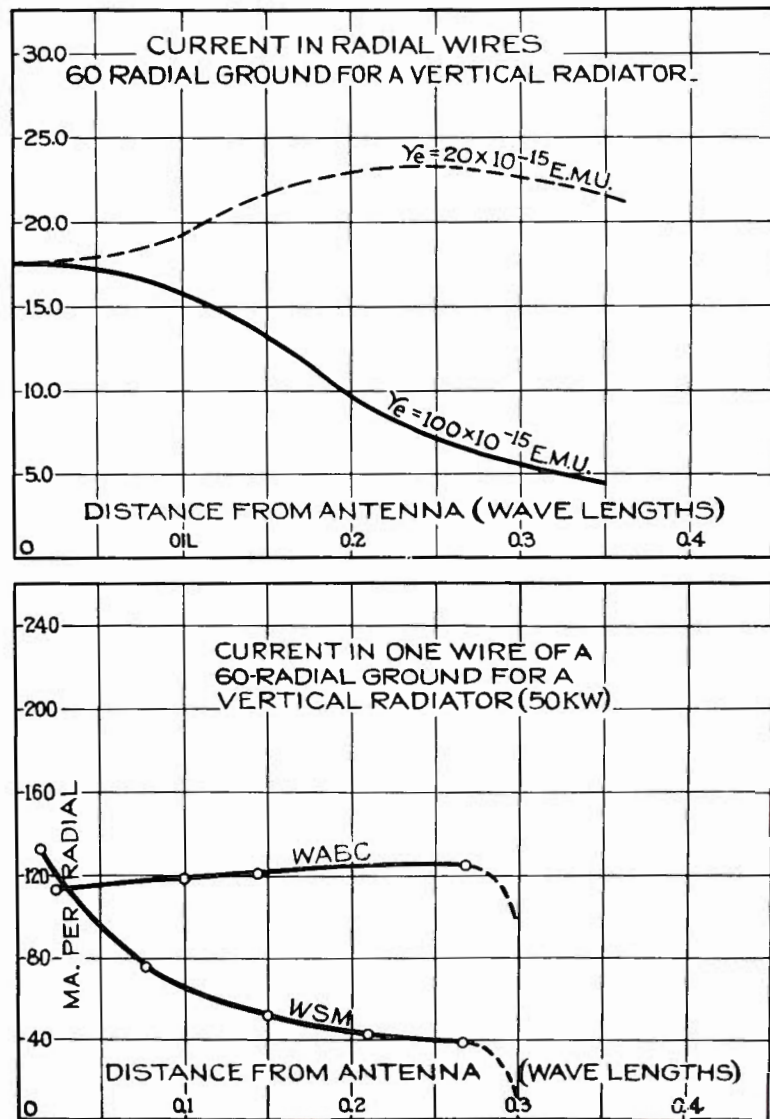

* Path, van der Pol. "The propagation of electromagnetic waves," Zeit. fur Hochfrequenz, vol. 37, April, (1931).

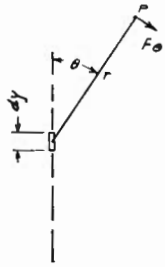

Figure 32

age conditions, at least 100 to 120 radials should be used. The wires need not be buried more than six to twelve inches. The wires, however, should be in the earth and not lying on the surface.

In Appendix C is given a discussion of the effect of base capacitance. It is shown that under the worst conditions in average practice, the power loss due to base insulator capacity is of the order of one to two per cent. The effect of this loss on the field intensity is the square root of this amount and the decrease in service radius is the square root of this latter figure, so that the effect of the losses in the base insulator capacitance can be said to be entirely negligible. It is true that the resistance and reactance values measured at the base of the tower will be different with and without capacity, the reason for which is obvious from a study of the results given in Appendix C. There is, however, no effect on the current distribution and hence no effect on the properties of the tower as a radiator. It is assumed that the only loss is due to the resistance component in the porcelain insulators. The capacity currents introduce no loss if they are properly conducted. This can be accomplished in practice by placing a large metal screen or mat on the surface of the earth below the antenna and tying this mat directly to the ground system.

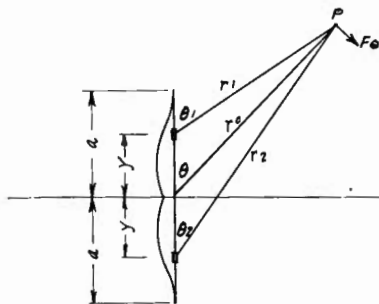

Figure 33

Owing to the difficulty of making measurements on a radio tower, much of their performance has been shrouded in mystery. The performance characteristics that are of value are current distribution on the antenna, vertical radiation pattern, and field intensity at one mile versus frequency for a constant power input. Current distribution on a large radio tower is almost impossible to obtain, vertical patterns are obtained only at great difficulty by means of airplane measurements, while the field strength on the ground as a function of frequency is easily obtained. This latter measurement can be made by varying the frequency, keeping I^2R into the antenna a constant, and measuring the field strength at a fixed point about one mile distant. This can be done at very small power. Unless the amount of base capacitance is known, resistance and reactance measurements are of little value. Static capacitance measurements are a total loss as far as gauging the performance of the tower as a radiator is concerned. Measurement of the fundamental frequency also tells nothing about the performance since the resonance point of an antenna does not fall at 90 degrees. It is usually in the vicinity of 80 to 88 degrees operation, and closer to 80 degrees for an antenna of large cross section.

Definite indications can be obtained which will show whether or not the current distribution is sinusoidal. These are:

1. By making magnetic flux density measurements as described in Part VI, and calculating the total earth current for a number of points up to one wavelength. Points should be spaced about 0.025λ up to about 0.3λ , 0.05λ up to 0.5λ , and 0.1λ up to one wavelength. This current can be plotted and compared to the curves of Fig. 26. For an antenna over 180 degrees, the earth current drops off rapidly, then begins to rise, and soon approaches a steady value. The general shape of the measured curve and the curve in Fig. 26 should be the same for an antenna of given electrical height if the antenna current distribution is sinusoidal. The

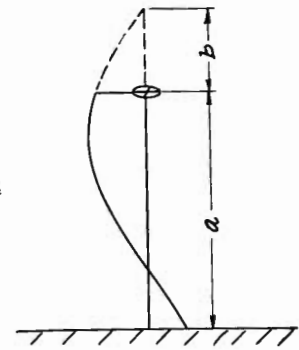

Figure 34

value at the base of the antenna, zero distance on the curve, will correspond to the true value of the antenna current. This may differ from the antenna current meter reading because of the effect of base insulator capacitance.

2. A field strength versus frequency curve from $a/\lambda = 0.25$ to $a/\lambda = 0.75$ as described should have the same shape as the calculated curve C shown on Fig. 16, with a peak at 230 degrees if the current distribution is sinusoidal.

3. If the equipment is available, a measurement of the vertical characteristic can be made. This should agree closely with the proper curve of Fig. 14.

Thus there are three indications from which a determination can be made as to whether the current distribution is sinusoidal. If these indications show that the current distribution is not sinusoidal, the only recourse is to build a model and measure the current distribution as described in Part II to determine the performance of the antenna.

Referring to Fig. 4, curves A and B, it can be seen that the effect of guys is not as detrimental as one might expect. Very little information is available concerning the effect of guys on the antenna characteristics. Experiments can be carried out by the method of models to determine the difference in performance, if any, between guyed and unguyed towers. It is interesting to note that in the flux density measurement close to the WCAU antenna, no important difference could be found in the readings taken along the radials running out close to the guy wires and those radials remote from the guy wires.

(To be continued in our next issue.)

IMPEDANCE MATCHING

(Continued from Page 11)

used for impedance expansion as well as reduction. In practice, the resistor values employed are not critical so that values within 5% of the computed table values will be satisfactory.

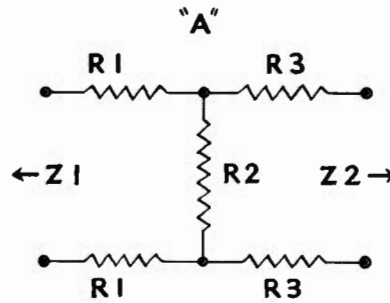

Impedance Matching Attenuation Network Data

(Resistance values in ohms)

Loss in DB	500-500			500-200			500-50			200-50		
	R1	R3	R2	R1	R2	R3	R1	R2	R3	R1	R2	R3
1	14.3	4333										
2	30	2150										
3	40	1430										
4	55	1050										
5	72.5	820										
6	82.5	670										
7	100	525										
8	107	476		Min. Loss	8.9 DB							
9	119.5	406	194.2	256.7	.63							
10	129	352	193.7	222.6	10.7					Min. Loss	11.4 DB	
15	174	184	207.8	116.3	43.2	Min. Loss	15.8 DB	88	36.8	8.2		
20	204.5	101	223	64	70	239	31.9	9.5	91.9	20.2	15.4	
25	223	56	233.3	35.4	82.7	242.1	17.7	16.2	94.8	11.2	19.5	
30	234.1	31.6	240	20	90	245	10	20	96.8	6.4	21.8	
35	241	17.7	244.3	11.2	94.3	247.2	5.6	22.2	98.2	3.6	23.2	
40	245	10	246.8	6.3	96.8	248.4	3.16	23.4	99	2	24	
45	247	5.6	248.2	3.5	98.2	249.1	1.78	24.1	99.5	1.12	24.5	
50	248.5	3.1	249	2	99	249.5	1	24.5	99.7	.64	24.7	
55	249.2	1.7	249.4	1.18	99.4	249.7	.58	24.7	99.7	.37	24.7	
60	249.5	1	249.4	.65	99.4	249.7	.32	24.7	99.8	.20	24.8	
65	249.8	.56	249.6	.39	99.6	249.8	.19	24.8	99.8	.12	24.8	
70	249.8	.31	249.8	.20	99.8	249.9	.10	24.9	99.9	.06	25	
75	249.9	.17	249.9	.12	99.9	249.9	.06	24.9	100	.04	25	
80	249.9	.10	249.9	.06	99.9	249.9	.03	24.9	100	.02	25	

Z1/Z2 or Z2/Z1	Min. Loss DB
1	0
1.5	5.73
2	7.67
2.5	8.94
3	9.96
4	11.42
5	12.50
6	13.46
8	14.79
10	15.80
12	16.65
16	17.98
20	18.96
25	19.94
100	26.00

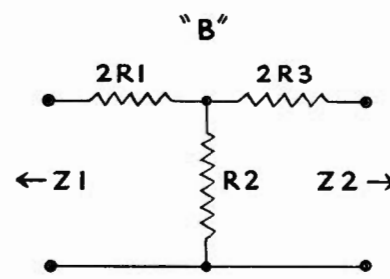

WIOD

(Continued from Page 13)

being mounted on the inner wall sections and sheet rock sections inserted in spring clips attached thereto. After a coating of brown plaster over the flexible sheet rock wall sections, two inches of rock wool was used on all side walls and four inches in the ceilings. The rock wool is covered with sheets of drilled celotex.

The studios incorporate the lat-

est developments of acoustical engineering. Absorbent surfaces in the large studio alternately oppose hard surfaces. The main studio is capable of accommodating a 65-piece symphony orchestra with ease. Infinite pains were taken with every technical detail of these studios, even to the sound-proof doors which are of the same type as those used in Radio City. There is an isolating sound-proofing

chamber between the small and large studios and corridor, allowing for two doors between the studios. These heavy doors are made up of cross grain wood sections between which are placed sheets of lead foil embedded in asphalt. The doors have an acoustic core and are self-sealing at the thresholds.

Both studios are most artistic. The large studio is decorated in a shade of ultra marine blue with silver trim, resembling chromium plate, and the grey ceiling is beamed with four counter sunk sections. This ceiling is decorated with a modernistic design embodying the symbols of radio transmission. Three sides of the large studio are decorated with grills, 7 x 18 ft. high, decorative and symbolizing radiation. They are back-lighted with blue and red neon. These grills are bordered with opalescent black glass, which offers a sharp contrast to the delicately blue shaded walls.

The control room windows, auxiliary window and inter-studio connecting window are all triple-glass of three varying thicknesses. Both studios have a modernistic announcers' desk, with individual microphone control and inter-connecting phones to the control room. The concrete floors of both studios as well as the floor of the control room are floating, resting upon spring chairs.

The approach to the studios is through the fourth floor elevation, which accommodates the offices of the Isle of Dreams Broadcasting Corporation.

These studios of WIOD are in truth, from an up-to-date engineering standpoint as well as that of beauty, the "Radio City of the South."

KSD

(Continued from Page 17)

amplifier to be thrown across either the studio output on the line to the transmitter. An additional 4194-B amplifier is located on the line terminating rack in control room "A" which feeds nine loud speakers located in various parts of the building. It has been found this amplifier provides more than sufficient volume to feed this number of speakers.

Asides at the N. A. B. Convention



Above: **H. C. Vance** adopts the tropical mode, hat and all. Unanimously chosen as the sartorial hit of the Convention.



No—you're wrong! This is not a scene from Little America. Just a group from the N.A.B. Convention who had to see Pike's Peak or bust.



Above: **Ted Smith**, evidently looking for new fields to conquer. The confines of Manhattan seem cramped when compared with the broad vistas of the Great West.



Not for **I. R. Baker** the cold and lofty heights. He is perfectly satisfied with "High Fidelity" and a cozy corner.

Below: **Ben Adler** in a pensive mood ponders Greeley's maxim, "Go West Young Man"—or could he be gazing Camden-ward?



Below: **W. H. Beltz** also shows a decided preference for the warmer climes.

Below: From left to right—**K. G. Marshall**, WBRC, Birmingham; **Howard Barth**, WSYR, Syracuse; **T. A. Smith**, RCA, New York; **S. H. Bliss**, WCLO, Janesville.



AS INDIVIDUAL AS A TAILORED GARMENT

BUT the tailor's problem is comparatively simple when compared with the complicated problems that confront the studio engineer. Speech Input Equipment must be specially designed for the station's needs to be efficient.

Whether it be KVSO, KSD, KNX, or WGN, there is an RCA solution for the problem.

Whether it be the control system for elaborate network productions or the simplified single channel arrangements for smaller stations the same care and thought is given to the solution of the problem.

Only RCA can bring to you the vast wealth of experience gained in the solution of unnumbered Speech Input Equipment questions, and only RCA can bring to you the highly specialized technical skill which will result in the speedy and satisfactory termination of your difficulty.

Don't hesitate to send in your studio problems. A complete stock of standard panels, designed for extreme flexibility, may be assembled to quickly and accurately fill your individual requirements.



TRANSMITTER SECTION
ENGINEERING PRODUCTS DIVISION
RCA MANUFACTURING CO., Inc.
CAMDEN, N. J.

New Vertical Radiator at WDOOD

RADIO station WDOOD in Chatanooga, Tenn., boasts a new half-wave vertical radiator recently built by the Truscon Steel Company of Youngstown, Ohio.

The results obtained with this new installation are reported as very gratifying, for the field intensity measurements show that the efficiency of this new antenna system is approximately twice that of their old antenna. Station WDOOD formerly had a single-wire T-type antenna suspended between two 110-foot wooden poles, one of which can be seen in the background of the tower picture.

During a recent visit of Benjamin Adler, of the Transmitter Section of the RCA Manufacturing Co., Inc., his picture was taken in some very prominent company. Beginning at the left in this picture are M. Eager, Engi-

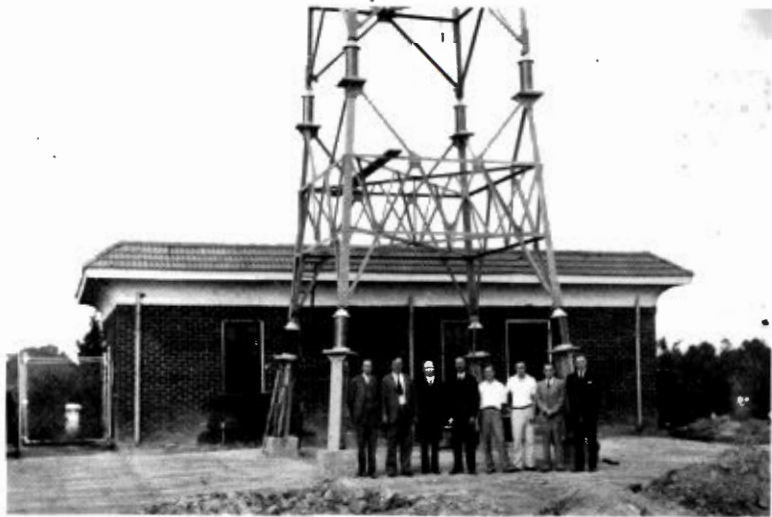

Group of notables outside the WDOOD transmitter building (see text)

neer for Glenn D. Gillett, who appears next; H. W. Grahl, District Manager of the Truscon Steel Company; E. W. Winger, Vice President of WDOOD; two members of the staff; Ben Adler (himself), and Norman A. Thomas,

President of WDOOD.

Station WDOOD has recently installed new RCA Victor studio amplifier, transcription turntable and microphone equipment, in line with the general improvement policy.

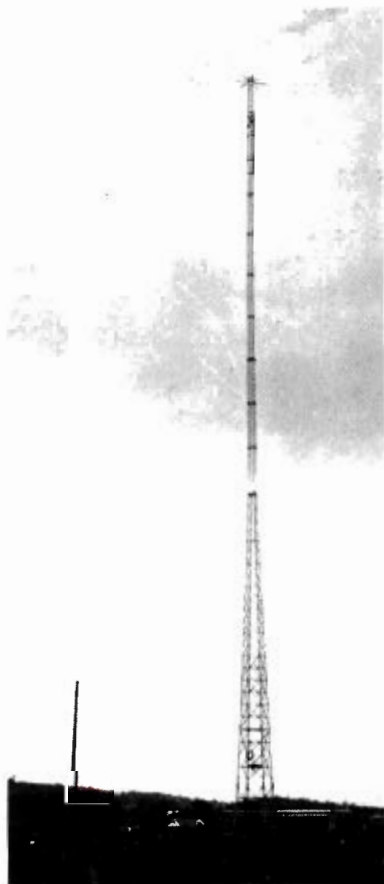

The new half-wave vertical radiator at WDOOD

WBEN Puts Curves on Air

WISHING to take frequency characteristics of the transmitter and speech equipment, WBEN in Buffalo utilized this as an opportunity to put on a unique program. R. J. Kingsley, Technical Director, secured permission from the supervisor of radio to broadcast the tests late on the evening of February 8th. Explaining that the station was to be modulated with varying tones, the announcer advised that listeners could calibrate their receiving sets and see how wide a band they could receive. Each tone was named as put on and in addition illustrations were given of the tones in various instruments of an orchestra and the importance of being able to receive the entire audible band was brought out.

The station received hundreds of telephone calls from interested listeners as well as many letters. Radio service men used the opportunity to check equipment and to calibrate apparatus.

An over-all curve was taken on WBEN from microphone terminals to the antenna. This curve has been combined with a velocity microphone curve to give the data on the station, including microphone, studio, amplifiers, telephone line to transmitter, and transmitter itself. A considerable amount of work has been done by Messrs. Kingsley and Horn to produce a flat characteristic on a 15-mile line.

WBEN uses an RCA 1-B transmitter and RCA speech input equipment throughout.

WBT Adds Vertical Radiator to RCA Transmitter

By WILLIAM A. SCHUDDT, Jr., General Manager, WBT

WBT, Southern Key Station of the Columbia Broadcasting System, in Charlotte, N. C., has a new and much stronger voice since the addition of a 435-foot vertical radiator to its modern 50,000 watt transmitter.

With the completion of WBT's new vertical radiator, the tallest man-made structure in the Carolinas, Charlotte's big 50,000-watt broadcasting station is now one of the most modern in the entire world.

With this new radiator giving WBT practically the equivalent of an increase of power to 100,000 watts, it is interesting to note that there is only one station in the United States with more power than WBT.

The new vertical radiator which was officially put into use December 19th, is a steel tower rising 435 feet in the air and balanced on a 10-inch insulator. The tower is held in place by four guy wires connected to its superstructure at approximately one-third its height. From its 10-inch base insulator, the tower rises to a width of 17 feet in its middle section, and tapers off to one foot in diameter at the top. It is not a mast for an antenna, it is the antenna itself radiating from each part of its 200 tons of steel the full volume of WBT's 50,000-watt transmitter.

Today, there are only fourteen vertical radiators in use throughout the entire world. Charlotte, N. C., has followed the example of New York, Philadelphia, Boston and Budapest, Hungary, in placing in use this, the most modern type transmitter radiator.

This is the latest chapter in a fast-moving panorama of success. WBT was the first station in the South, beginning its broadcasting on April 7, 1921, when only 250 watts of power carried its programs to a limited audience. From then on, progress was rapid and



The New Vertical Radiator installed at Station WBT, Charlotte, N. C.
This tower is 435 feet high

the station grew in power and popularity from year to year. A little over a year ago, December 13, 1933, WBT installed its new 50,000-watt transmitter ten miles southeast of Charlotte, and on December 19, 1934, exactly one year and six days later, it added the revolutionary vertical radiator to its equally modern equipment.

As WBT now goes on the air, its power has been multiplied two-hundredfold over that employed in 1921. Utilizing the nationally cleared channel of 1080 kilocycles, WBT's powerful voice now not only penetrates every city and town in the United States but is

received consistently and strongly in such far-away places as Australia, New Zealand, England, France, Holland, Germany, South America, and, of course Canada and Mexico. Following the all-night broadcast marking the first full day of operation with the new vertical radiator, WBT received hundreds of wires, letters and phone calls from all parts of the world, commenting on the increased strength with which that station's programs were received. Even before the all-night program had ended cables had been received from England, Hawaii, and also

(Continued on Page 17)

New Vertical Radiator at WDOD

RADIO station WDOD in Chatanooga, Tenn., boasts a new half-wave vertical radiator recently built by the Truscon Steel Company of Youngstown, Ohio.

The results obtained with this new installation are reported as very gratifying, for the field intensity measurements show that the efficiency of this new antenna system is approximately twice that of their old antenna. Station WDOD formerly had a single-wire T-type antenna suspended between two 110-foot wooden poles, one of which can be seen in the background of the tower picture.

During a recent visit of Benjamin Adler, of the Transmitter Section of the RCA Manufacturing Co., Inc., his picture was taken in some very prominent company. Beginning at the left in this picture are M. Eager, Engi-

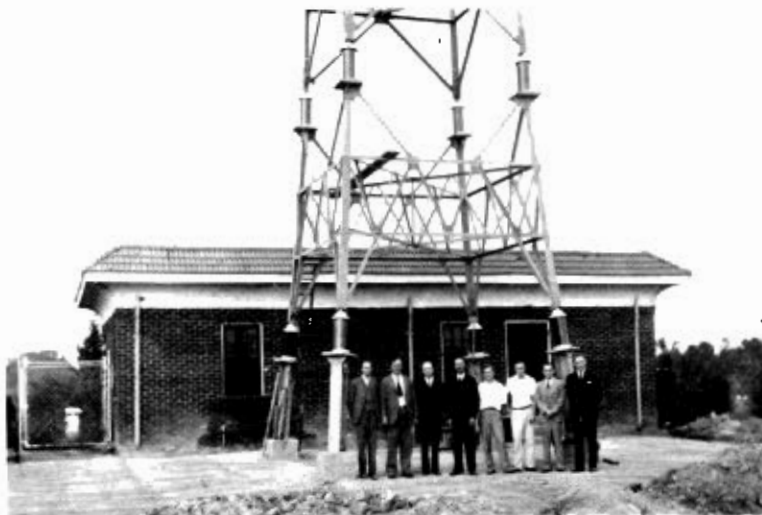

Group of notables outside the WDOD transmitter building (see text)

neer for Glenn D. Gillett, who appears next; H. W. Grahl, District Manager of the Truscon Steel Company; E. W. Winger, Vice President of WDOD; two members of the staff; Ben Adler (himself), and Norman A. Thomas,

President of WDOD.

Station WDOD has recently installed new RCA Victor studio amplifier, transcription turntable and microphone equipment, in line with the general improvement policy.

WBEN Puts Curves on Air

WISHING to take frequency characteristics of the transmitter and speech equipment, WBEN in Buffalo utilized this as an opportunity to put on a unique program. R. J. Kingsley, Technical Director, secured permission from the supervisor of radio to broadcast the tests late on the evening of February 8th. Explaining that the station was to be modulated with varying tones, the announcer advised that listeners could calibrate their receiving sets and see how wide a band they could receive. Each tone was named as put on and in addition illustrations were given of the tones in various instruments of an orchestra and the importance of being able to receive the entire audible band was brought out.

The station received hundreds of telephone calls from interested listeners as well as many letters. Radio service men used the opportunity to check equipment and to calibrate apparatus.

An over-all curve was taken on WBEN from microphone terminals to the antenna. This curve has been combined with a velocity microphone curve to give the data on the station, including microphone, studio, amplifiers, telephone line to transmitter, and transmitter itself. A considerable amount of work has been done by Messrs. Kingsley and Horn to produce a flat characteristic on a 15-mile line.

WBEN uses an RCA I-B transmitter and RCA speech input equipment throughout.



The new half-wave vertical radiator at WDOD

WBT Adds Vertical Radiator to RCA Transmitter

By WILLIAM A. SCHUDT, Jr., General Manager, WBT

WBT, Southern Key Station of the Columbia Broadcasting System, in Charlotte, N. C., has a new and much stronger voice since the addition of a 435-foot vertical radiator to its modern 50,000 watt transmitter.

With the completion of WBT's new vertical radiator, the tallest man-made structure in the Carolinas, Charlotte's big 50,000-watt broadcasting station is now one of the most modern in the entire world.

With this new radiator giving WBT practically the equivalent of an increase of power to 100,000 watts, it is interesting to note that there is only one station in the United States with more power than WBT.

The new vertical radiator which was officially put into use December 19th, is a steel tower rising 435 feet in the air and balanced on a 10-inch insulator. The tower is held in place by four guy wires connected to its superstructure at approximately one-third its height. From its 10-inch base insulator, the tower rises to a width of 17 feet in its middle section, and tapers off to one foot in diameter at the top. It is not a mast for an antenna, it is the antenna itself radiating from each part of its 200 tons of steel the full volume of WBT's 50,000-watt transmitter.

Today, there are only fourteen vertical radiators in use throughout the entire world. Charlotte, N. C., has followed the example of New York, Philadelphia, Boston and Budapest, Hungary, in placing in use this, the most modern type transmitter radiator.

This is the latest chapter in a fast-moving panorama of success. WBT was the first station in the South, beginning its broadcasting on April 7, 1921, when only 250 watts of power carried its programs to a limited audience. From then on, progress was rapid and

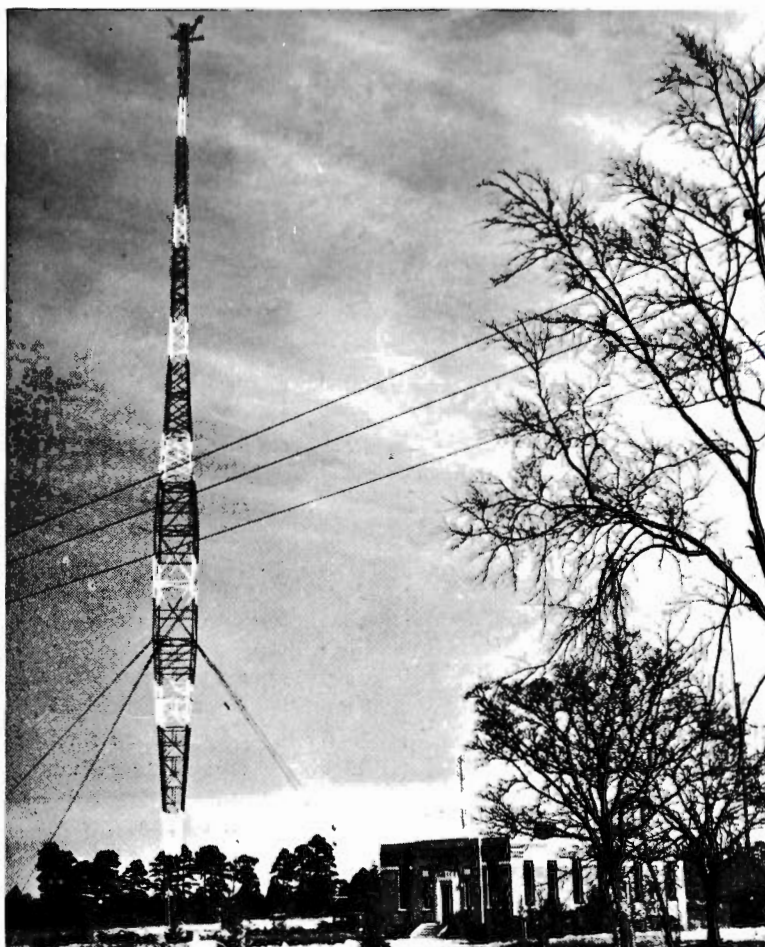

The New Vertical Radiator installed at Station **WBT**, Charlotte, N. C.
This tower is 435 feet high

the station grew in power and popularity from year to year. A little over a year ago, December 13, 1933, WBT installed its new 50,000-watt transmitter ten miles southeast of Charlotte, and on December 19, 1934, exactly one year and six days later, it added the revolutionary vertical radiator to its equally modern equipment.

As WBT now goes on the air, its power has been multiplied two-hundredfold over that employed in 1921. Utilizing the nationally cleared channel of 1080 kilocycles, WBT's powerful voice now not only penetrates every city and town in the United States but is

received consistently and strongly in such far-away places as Australia, New Zealand, England, France, Holland, Germany, South America, and, of course Canada and Mexico. Following the all-night broadcast marking the first full day of operation with the new vertical radiator, WBT received hundreds of wires, letters and phone calls from all parts of the world, commenting on the increased strength with which that station's programs were received. Even before the all-night program had ended cables had been received from England, Hawaii, and also

(Continued on Page 17)

New Vertical Radiator at WDOD

RADIO station WDOD in Chatanooga, Tenn., boasts a new half-wave vertical radiator recently built by the Truscon Steel Company of Youngstown, Ohio.

The results obtained with this new installation are reported as very gratifying, for the field intensity measurements show that the efficiency of this new antenna system is approximately twice that of their old antenna. Station WDOD formerly had a single-wire T-type antenna suspended between two 110-foot wooden poles, one of which can be seen in the background of the tower picture.

During a recent visit of Benjamin Adler, of the Transmitter Section of the RCA Manufacturing Co., Inc., his picture was taken in some very prominent company. Beginning at the left in this picture are M. Eager, Engi-

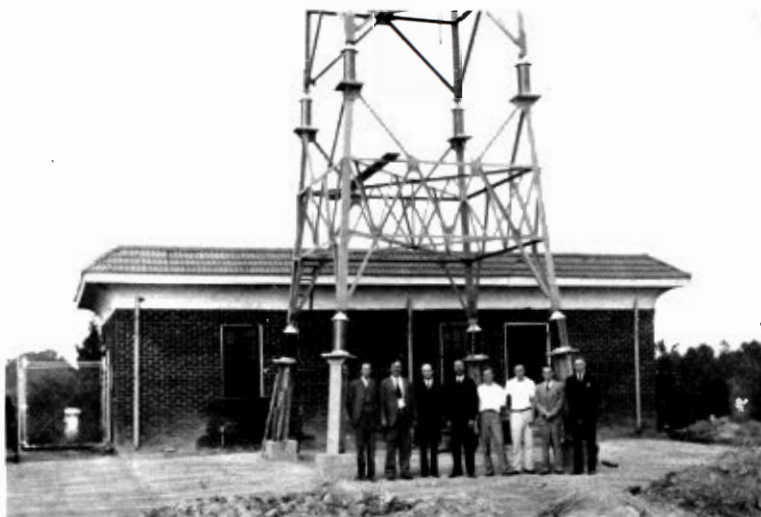

Group of notables outside the WDOD transmitter building (see text)

neer for Glenn D. Gillett, who appears next; H. W. Grahl, District Manager of the Truscon Steel Company; E. W. Winger, Vice President of WDOD; two members of the staff; Ben Adler (himself), and Norman A. Thomas,

President of WDOD.

Station WDOD has recently installed new RCA Victor studio amplifier, transcription turntable and microphone equipment, in line with the general improvement policy.

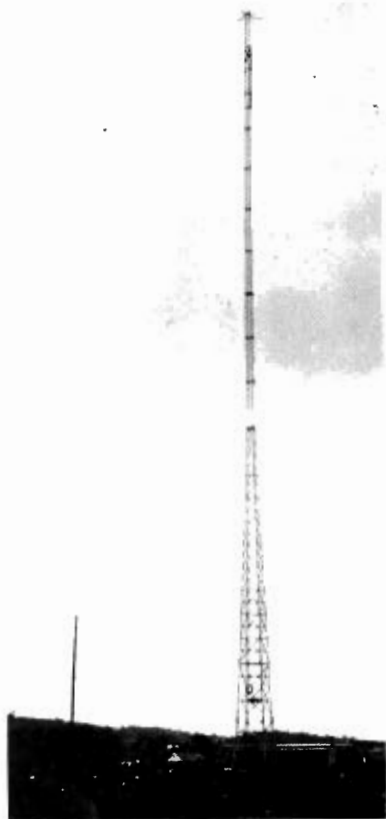

The new half-wave vertical radiator at WDOD

WBEN Puts Curves on Air

WISHING to take frequency characteristics of the transmitter and speech equipment, WBEN in Buffalo utilized this as an opportunity to put on a unique program. R. J. Kingsley, Technical Director, secured permission from the supervisor of radio to broadcast the tests late on the evening of February 8th. Explaining that the station was to be modulated with varying tones, the announcer advised that listeners could calibrate their receiving sets and see how wide a band they could receive. Each tone was named as put on and in addition illustrations were given of the tones in various instruments of an orchestra and the importance of being able to receive the entire audible band was brought out.

The station received hundreds of telephone calls from interested listeners as well as many letters. Radio service men used the opportunity to check equipment and to calibrate apparatus.

An over-all curve was taken on WBEN from microphone terminals to the antenna. This curve has been combined with a velocity microphone curve to give the data on the station, including microphone, studio, amplifiers, telephone line to transmitter, and transmitter itself. A considerable amount of work has been done by Messrs. Kingsley and Horn to produce a flat characteristic on a 15-mile line.

WBEN uses an RCA 1-B transmitter and RCA speech input equipment throughout.

WBT Adds Vertical Radiator to RCA Transmitter

By WILLIAM A. SCHUDT, Jr., General Manager, WBT

WBT, Southern Key Station of the Columbia Broadcasting System, in Charlotte, N. C., has a new and much stronger voice since the addition of a 435-foot vertical radiator to its modern 50,000 watt transmitter.

With the completion of WBT's new vertical radiator, the tallest man-made structure in the Carolinas, Charlotte's big 50,000-watt broadcasting station is now one of the most modern in the entire world.

With this new radiator giving WBT practically the equivalent of an increase of power to 100,000 watts, it is interesting to note that there is only one station in the United States with more power than WBT.

The new vertical radiator which was officially put into use December 19th, is a steel tower rising 435 feet in the air and balanced on a 10-inch insulator. The tower is held in place by four guy wires connected to its superstructure at approximately one-third its height. From its 10-inch base insulator, the tower rises to a width of 17 feet in its middle section, and tapers off to one foot in diameter at the top. It is not a mast for an antenna, it is the antenna itself radiating from each part of its 200 tons of steel the full volume of WBT's 50,000-watt transmitter.

Today, there are only fourteen vertical radiators in use throughout the entire world. Charlotte, N. C., has followed the example of New York, Philadelphia, Boston and Budapest, Hungary, in placing in use this, the most modern type transmitter radiator.

This is the latest chapter in a fast-moving panorama of success. WBT was the first station in the South, beginning its broadcasting on April 7, 1921, when only 250 watts of power carried its programs to a limited audience. From then on, progress was rapid and

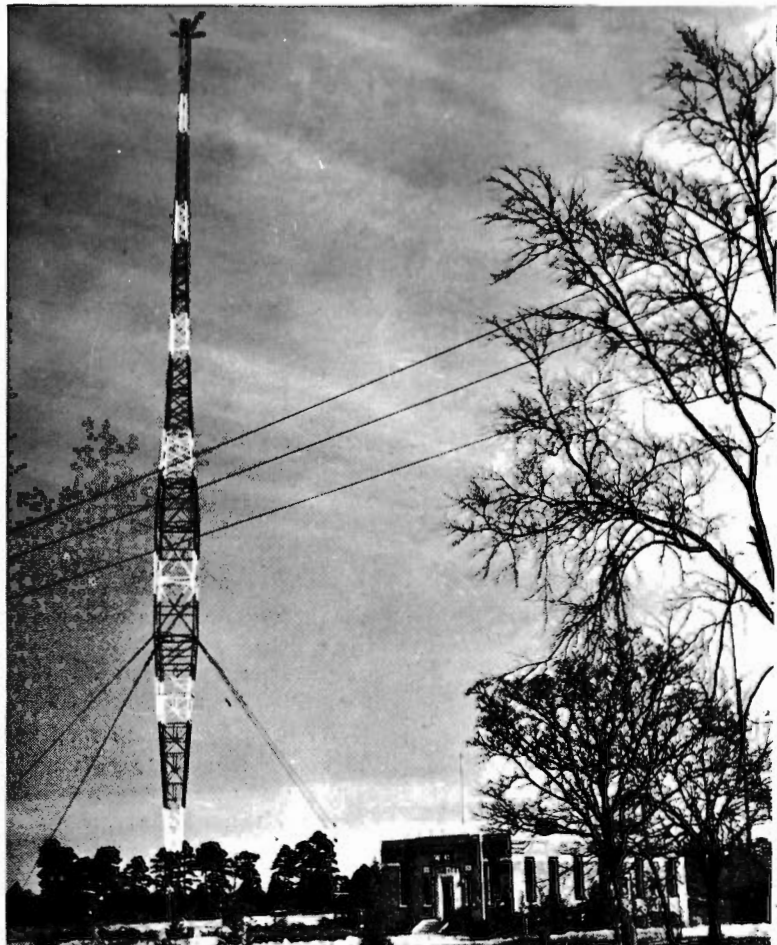

The New Vertical Radiator installed at Station WBT, Charlotte, N. C.
This tower is 435 feet high

the station grew in power and popularity from year to year. A little over a year ago, December 13, 1933, WBT installed its new 50,000-watt transmitter ten miles southeast of Charlotte, and on December 19, 1934, exactly one year and six days later, it added the revolutionary vertical radiator to its equally modern equipment.

As WBT now goes on the air, its power has been multiplied two-hundredfold over that employed in 1921. Utilizing the nationally cleared channel of 1080 kilocycles, WBT's powerful voice now not only penetrates every city and town in the United States but is

received consistently and strongly in such far-away places as Australia, New Zealand, England, France, Holland, Germany, South America, and, of course Canada and Mexico. Following the all-night broadcast marking the first full day of operation with the new vertical radiator, WBT received hundreds of wires, letters and phone calls from all parts of the world, commenting on the increased strength with which that station's programs were received. Even before the all-night program had ended cables had been received from England, Hawaii, and also

(Continued on Page 17)

New Vertical Radiator at WDOOD

RADIO station WDOOD in Chatanooga, Tenn., boasts a new half-wave vertical radiator recently built by the Truscon Steel Company of Youngstown, Ohio.

The results obtained with this new installation are reported as very gratifying, for the field intensity measurements show that the efficiency of this new antenna system is approximately twice that of their old antenna. Station WDOOD formerly had a single-wire T-type antenna suspended between two 110-foot wooden poles, one of which can be seen in the background of the tower picture.

During a recent visit of Benjamin Adler, of the Transmitter Section of the RCA Manufacturing Co., Inc., his picture was taken in some very prominent company. Beginning at the left in this picture are M. Eager, Engi-

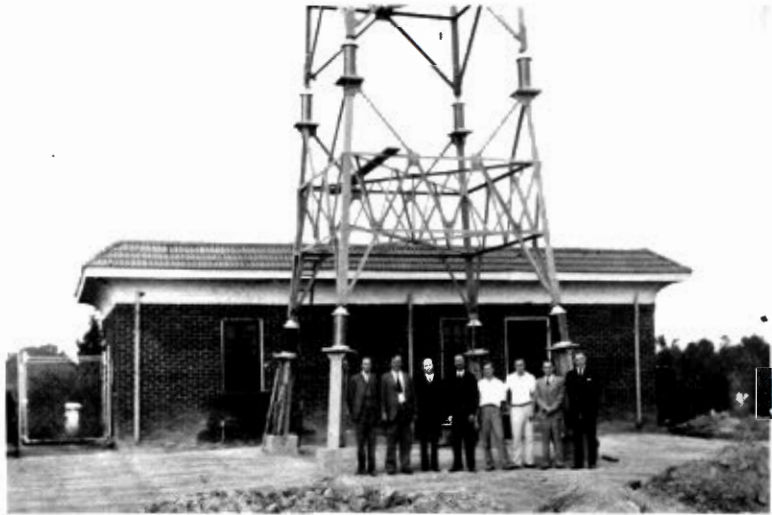

Group of notables outside the WDOOD transmitter building (see text)

neer for Glenn D. Gillett, who appears next; H. W. Grahl, District Manager of the Truscon Steel Company; E. W. Winger, Vice President of WDOOD; two members of the staff; Ben Adler (himself), and Norman A. Thomas,

President of WDOOD.

Station WDOOD has recently installed new RCA Victor studio amplifier, transcription turntable and microphone equipment, in line with the general improvement policy.

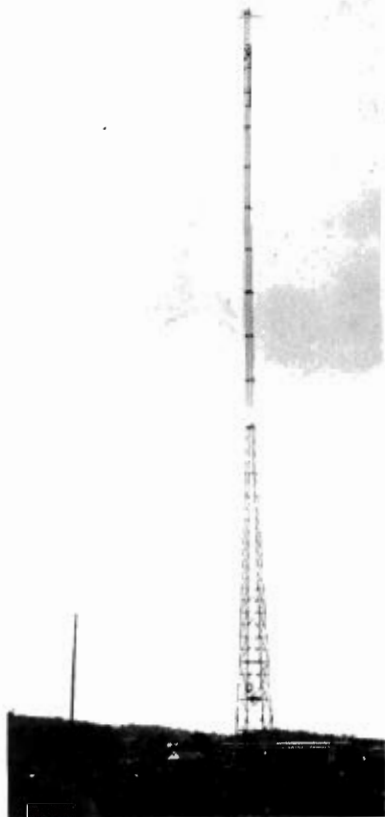

The new half-wave vertical radiator at WDOOD

WBEN Puts Curves on Air

WISHING to take frequency characteristics of the transmitter and speech equipment, WBEN in Buffalo utilized this as an opportunity to put on a unique program. R. J. Kingsley, Technical Director, secured permission from the supervisor of radio to broadcast the tests late on the evening of February 8th. Explaining that the station was to be modulated with varying tones, the announcer advised that listeners could calibrate their receiving sets and see how wide a band they could receive. Each tone was named as put on and in addition illustrations were given of the tones in various instruments of an orchestra and the importance of being able to receive the entire audible band was brought out.

The station received hundreds of telephone calls from interested listeners as well as many letters. Radio service men used the opportunity to check equipment and to calibrate apparatus.

An over-all curve was taken on WBEN from microphone terminals to the antenna. This curve has been combined with a velocity microphone curve to give the data on the station, including microphone, studio, amplifiers, telephone line to transmitter, and transmitter itself. A considerable amount of work has been done by Messrs. Kingsley and Horn to produce a flat characteristic on a 15-mile line.

WBEN uses an RCA 1-B transmitter and RCA speech input equipment throughout.

WBT Adds Vertical Radiator to RCA Transmitter

By WILLIAM A. SCHUDT, Jr., General Manager, WBT

WBT, Southern Key Station of the Columbia Broadcasting System, in Charlotte, N. C., has a new and much stronger voice since the addition of a 435-foot vertical radiator to its modern 50,000 watt transmitter.

With the completion of WBT's new vertical radiator, the tallest man-made structure in the Carolinas, Charlotte's big 50,000-watt broadcasting station is now one of the most modern in the entire world.

With this new radiator giving WBT practically the equivalent of an increase of power to 100,000 watts, it is interesting to note that there is only one station in the United States with more power than WBT.

The new vertical radiator which was officially put into use December 19th, is a steel tower rising 435 feet in the air and balanced on a 10-inch insulator. The tower is held in place by four guy wires connected to its superstructure at approximately one-third its height. From its 10-inch base insulator, the tower rises to a width of 17 feet in its middle section, and tapers off to one foot in diameter at the top. It is not a mast for an antenna, it is the antenna itself radiating from each part of its 200 tons of steel the full volume of WBT's 50,000-watt transmitter.

Today, there are only fourteen vertical radiators in use throughout the entire world. Charlotte, N. C., has followed the example of New York, Philadelphia, Boston and Budapest, Hungary, in placing in use this, the most modern type transmitter radiator.

This is the latest chapter in a fast-moving panorama of success. WBT was the first station in the South, beginning its broadcasting on April 7, 1921, when only 250 watts of power carried its programs to a limited audience. From then on, progress was rapid and



The New Vertical Radiator installed at Station WBT, Charlotte, N. C.
This tower is 435 feet high

the station grew in power and popularity from year to year. A little over a year ago, December 13, 1933, WBT installed its new 50,000-watt transmitter ten miles southeast of Charlotte, and on December 19, 1934, exactly one year and six days later, it added the revolutionary vertical radiator to its equally modern equipment.

As WBT now goes on the air, its power has been multiplied two-hundredfold over that employed in 1921. Utilizing the nationally cleared channel of 1080 kilocycles, WBT's powerful voice now not only penetrates every city and town in the United States but is

received consistently and strongly in such far-away places as Australia, New Zealand, England, France, Holland, Germany, South America, and, of course Canada and Mexico. Following the all-night broadcast marking the first full day of operation with the new vertical radiator, WBT received hundreds of wires, letters and phone calls from all parts of the world, commenting on the increased strength with which that station's programs were received. Even before the all-night program had ended cables had been received from England, Hawaii, and also

(Continued on Page 17)